

# ASSEMBLY AND INSTALLATION INSTRUCTIONS FOR ECLISSE CURVED SLIDING POCKET DOOR KITS

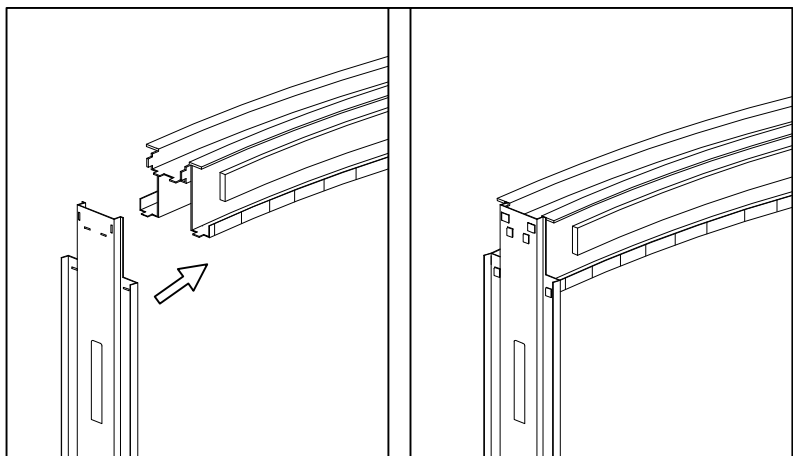

**Step 1** Remove the metal door post from the rear of the pocket and attach to the end of the track by inserting and bending over the metal tongues.



**Step 2** Insert the two spacers into their predetermined location points as shown

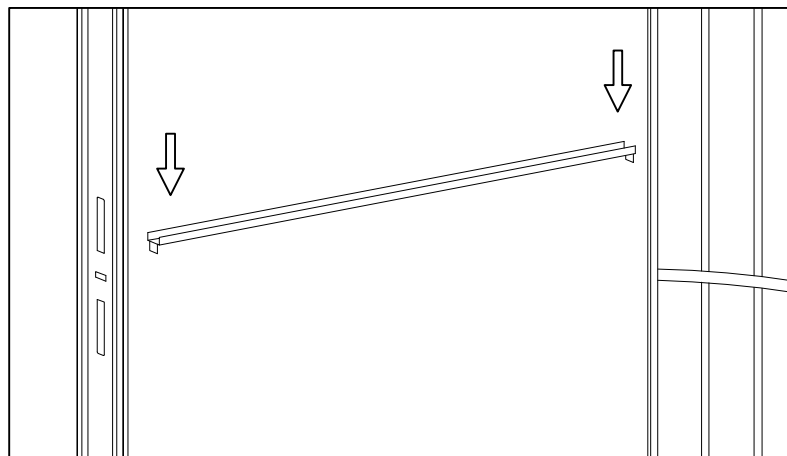

**Step 3** Centralise the frame between the stud work and check for alignment by looking down a sight line between the vertical of the metal door post and the edge of the pocket entrance, these two vertical sight lines should be PERFECTLY parallel. Screw the metal door post through the metal doorpost (a pair of screws every 50cm) to it's side of the stud work ensuring it is EXACTLY plumb and checking the sight line at all times.

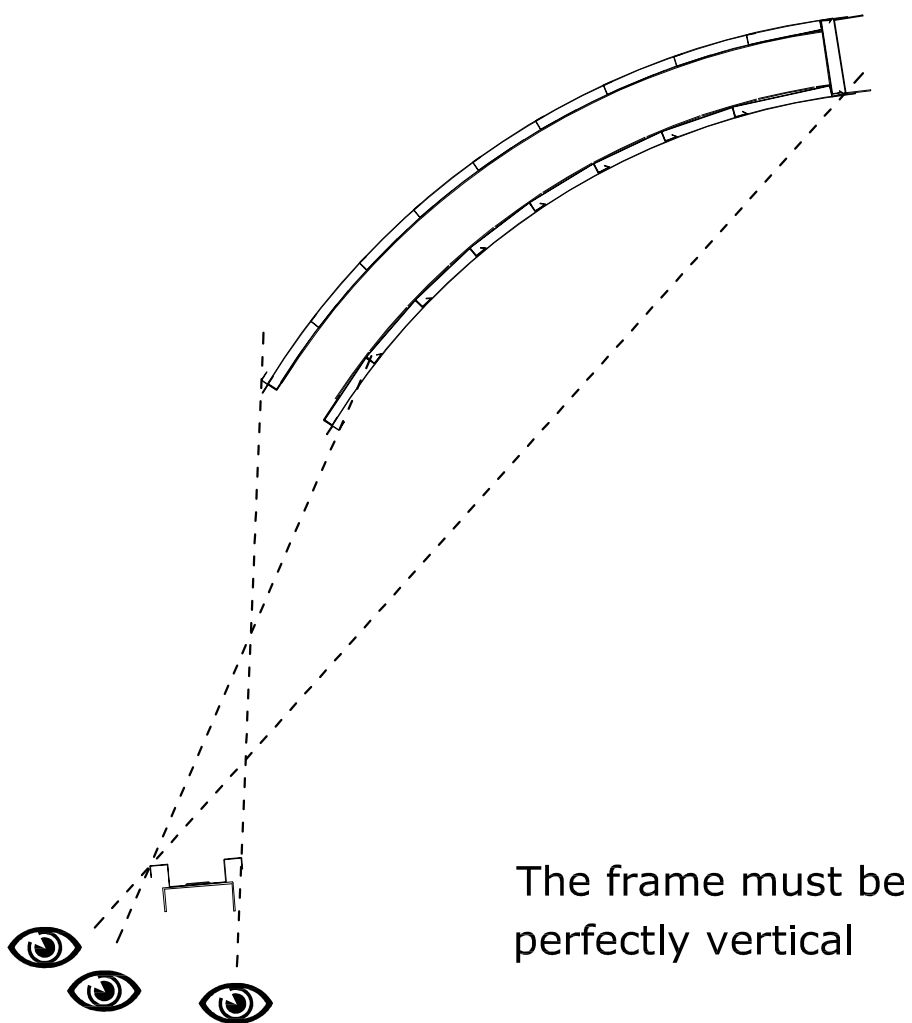

**Step 4** Screw through the stud work at the rear of the pocket into the rear pocket vertical (a pair of screws every 50cm)

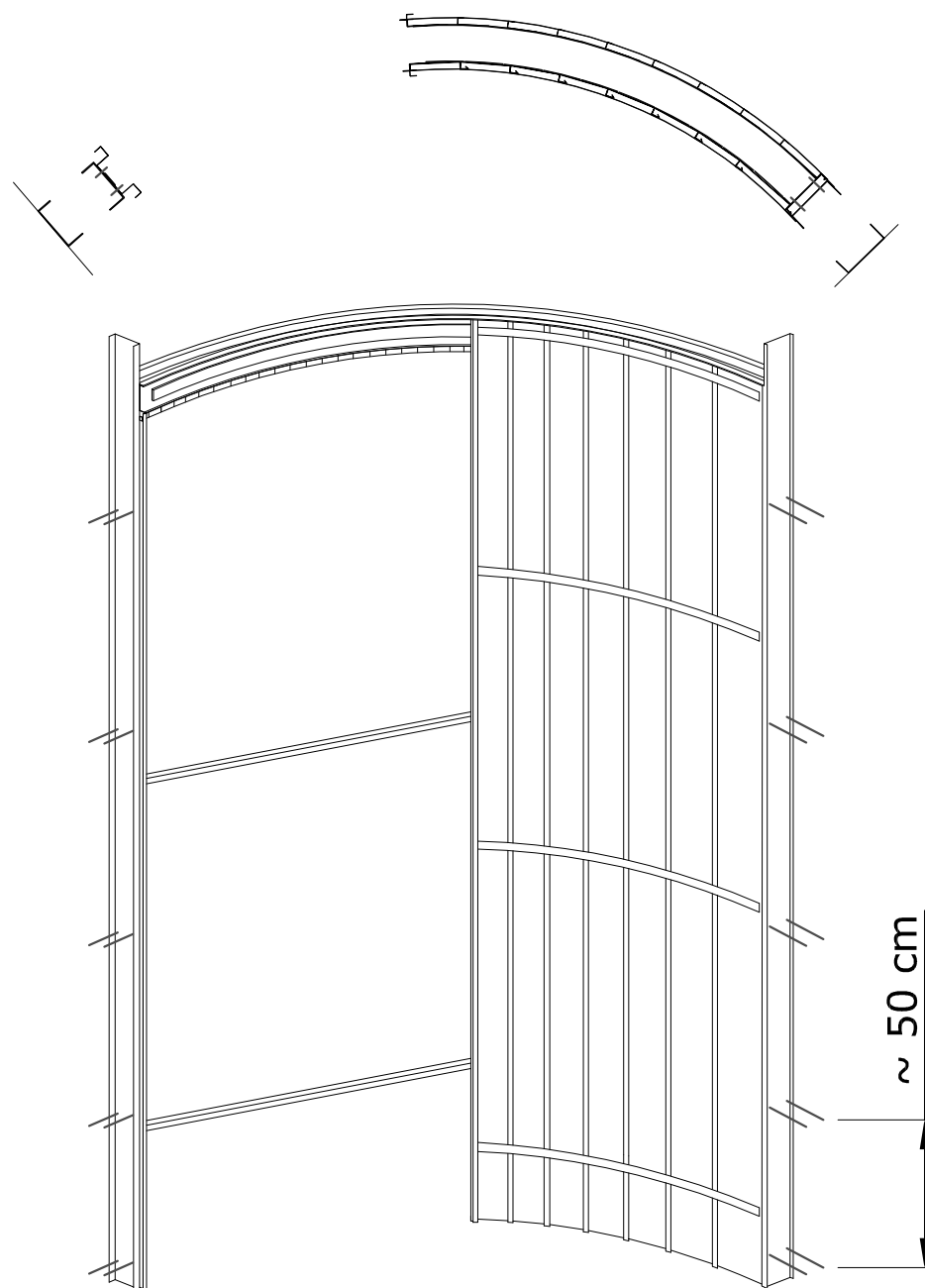

**Step 5** Screw the bottom pocket plate to the finished floor at the entrance to the pocket.

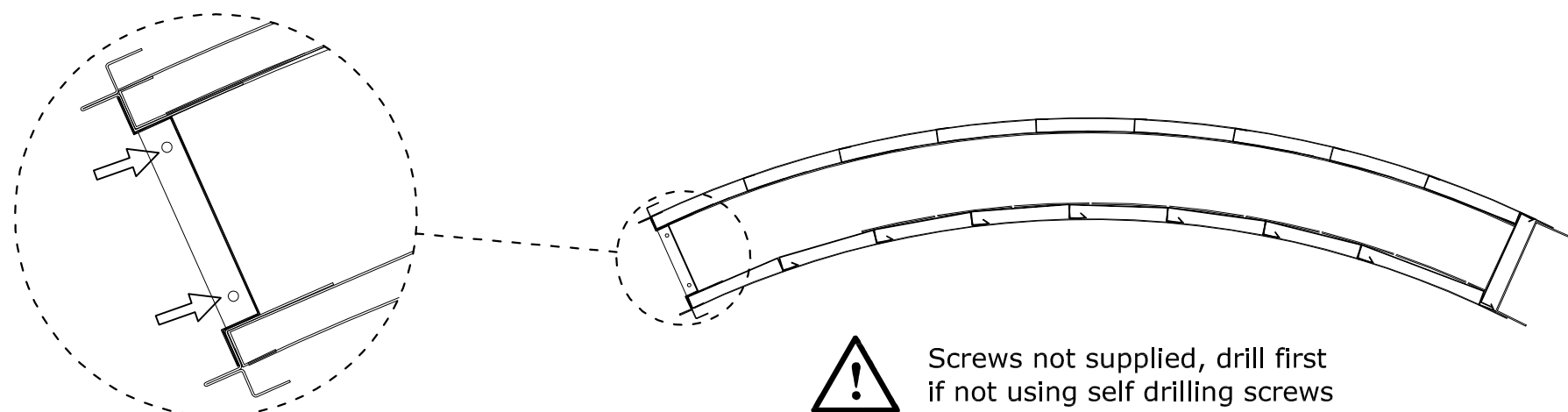

**Step 6** Fix the top rail to the stud work above the rail by drilling holes in the outer wings of the rail and screwing into the stud work. If you are using wooden stud then a screw each side every 40 cm. is adequate. If using a cut metal stud to obtain the curvature it is recommended that each cut section is screwed to the top stud work.

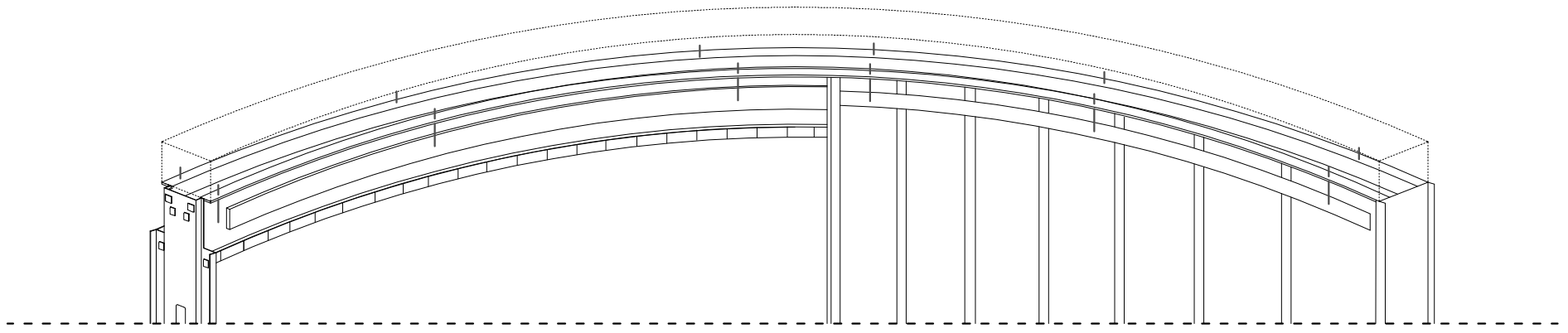

**Step 7** FIXING THE PLASTERBOARD TO THE FRAME

Two layers of 6 mm plasterboard are required (not supplied) and should be attached vertically and not horizontally. Included with the runner kit you will find a pack of black plasterboard screws to be used for attaching the plasterboard to the frame. Please note, plasterboard should be dampened well with water and curved to the approximate curvature of the frame. If the plasterboard is trying to spring back to straight when attaching to the frame this will pull the verticals at the entrance to the pocket out of line. **THIS MUST BE AVOIDED ABSOLUTELY** for the system to work correctly and the plasterboard should be re-dampened until there is no spring-back.

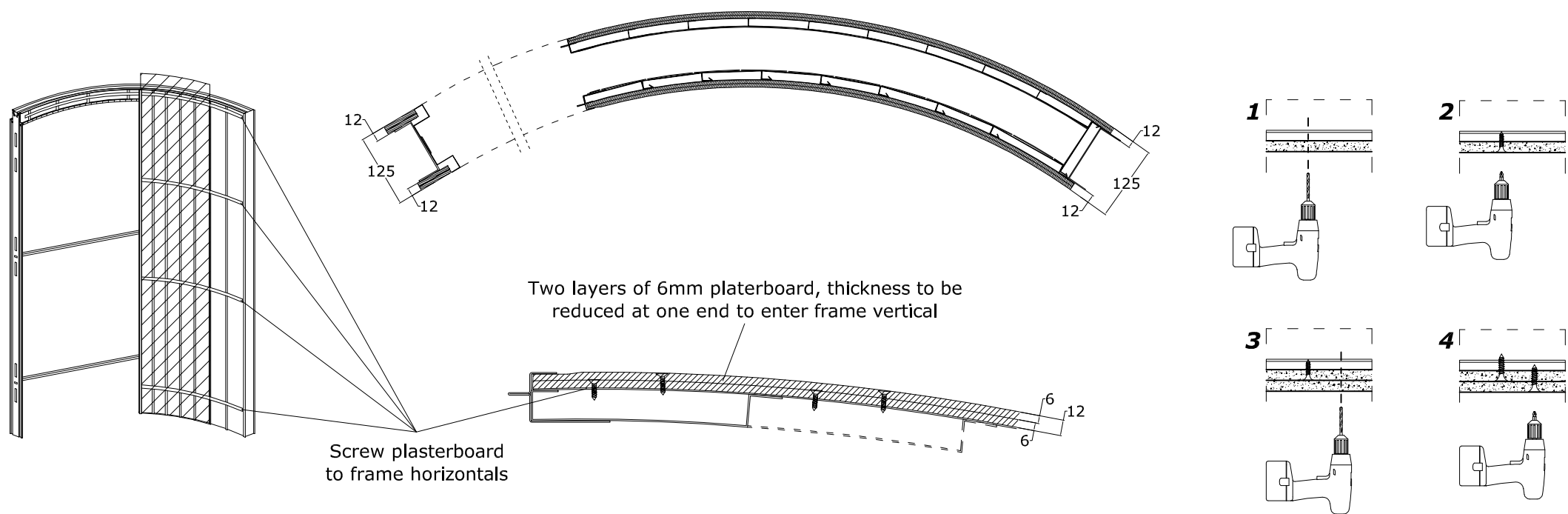

**Step 8** Remove and dispose of the vertical pocket entrance plate.

## INSTRUCTIONS FOR DOUBLE CURVED DOORS

READ THE INSTRUCTIONS FOR SINGLE CURVED UNITS.

Double door systems are supplied with the external and internal track faces unassembled. Each separate pocket should be positioned correctly and then the track faces attached. It is important the pockets are correctly positioned and you can check the pocket entrances are parallel by looking down a sight line between opposite ones from each pocket.

Obviously there are no door metal or wooden door posts so the instructions for the door posts can be ignored for double door systems.

The top track is attached to the stud work in a different manner for double units. Using the ties supplied attach them to the track system and the studwork above the unit ensuring they are securely fastened.

