

- | | |
|-----------------------------------------------------------------------------------------------------------------------------------------------------------------------------------------------------------------------------------------------------------------------------------------------------------------------------------------------------------------------------------------------------------------------------------------------------------------------------------------------------------------------------------------------------------------------------------------------------------------------------------------------------------------------------------------------------------------------------------------------------------------------------------------------------------------------------------------------------------------------------------------------------------------------------------------------------------------------------------------------------------------------------------------------------------------------------------------------------------------------------------------------------------------------------------------------------------------------------------------------------------------------------------------------------------------------------------------------------------|--------------------------------------------------------------------------------------------------------------------------------------------------------------------------------------------------------------------------------------------------------------------------------------------------------------------------------------------------------------------------------------------------------------------------------------------------------------------------------------------------------------------------------------------------------------------------------------------------------------------------------------------------------------------------------------------------------------------------------------------------------------------------------------------------------------------------------------------------------------------------------------------------------------------------------------------------------------------------------------------------------------------------------------------------------------------------------------------------------------------------------------------------------------------------------------|
| <p>IT MONTAGGIO CONTROTELAIO KIT SYNTESIS® BATTENTE 40 CARTONGESSO (pag.8) INTONACO (pag.12) - TIRARE</p> <p>GB SYNTESIS® BATTENTE 40 HINGED FRAME - INSTALLATION STUD WALL (page 8) SOLID WALL (page 12) - PULL</p> <p>PT INSTRUÇÕES DE MONTAGEM DE CAIXILHO SYNTESIS® BATTENTE 40 EM KIT PARA PAREDE EM GESSO CARTONADO (pág.8) ALVENARIA (pág.12) - PUXAR</p> <p>CZ MONTÁŽ STAVEBNÍ ZÁRUBNĚ KIT SYNTESIS® BATTENTE 40 DO SÁDROKARTONU (str.8) ZDIVO (str.12) - OTVÍRANÉ K SOBĚ</p> <p>SK MONTÁŽ SKRYTEJ ZÁRUBNE PRE OTOČNÉ DVERE KIT SYNTESIS® BATTENTE 40 DO SADROKARTÓNU (str. 8) DO MURIVA (str. 12) - ŤAHANÉ</p> <p>ES INSTALACIÓN CONTRAMARCO KIT SYNTESIS® BATTENTE 40 CARTÓN-YESO (pág. 8) ENLUCIDO (pág. 12) - TIRAR</p> <p>NL OPBOUW EN INSTALLATIE VAN HET SYNTESIS® BATTENTE 40 DRAAIDEUR KOZIJN GIPSPLAAT AFWERKING (pag. 8) PLEISTERWERK (pag. 12) - TREK-VERSIE</p> <p>FR ASSEMBLAGE ET POSE DE L'HUISSERIE EN KIT SYNTESIS® BATTENTE 40 POUR PORTES BATTANTES VERSION PLAQUE DE PLÂTRE (PAGE 8) VERSION À ENDUIRE (PAGE 12) - À TIRER</p> <p>DE MONTAGE DES EINBAUKASTEN KIT SYNTESIS® BATTENTE 40 TÜRLÜGEL GIPSKARTON (S.8) VERPUTZ (S.12) - ZIEHEN</p> | <p>PL MONTAŻ OŚCIEŻNICY ALUMINIOWEJ STANDARD 40 DO DRZWI ROZWIERNYCH DO ŚCIANY GIPSOWO-KARTONOWEJ (str. 8), MUROWANEJ (str. 12) DRZWI OTWIERANE TRADYCYJNIE</p> <p>RU МОНТАЖ ДВЕРНОЙ КОРОБКИ КИТ SYNTESIS® BATTENTE 40, ОТКРЫВАНИЕ - «НА СЕБЯ» ПОД ГИПСОКАРТОН (СТР.8) ПОД ШТУКАТУРКУ (СТР.12)</p> <p>RO INSTALARE KIT RAMĂ SYNTESIS® BATTENTE 40 GIPS CARTON (pag. 8) TENCUIALĂ (pag. 12) - TRAGE</p> <p>SI NAMESTITEV OGRODJA KIT SYNTESIS® BATTENTE 40 Z VRATNICO IZ MAVČNEGA KARTONA (str.8) OMET (str.12) - NA VLEKO</p> <p>HU SYNTESIS® BATTENTE 40 KIT NYÍLÓ AJTÓ SZERKEZETHEZ GIPSZKARTON (8. old) ÉS VAKOLHATÓ FALHOZ (12. old) - HÚZNI</p> <p>HR MONTAŽA KIT-A PROTU-OKVIRA VRATA SYNTESIS® BATTENTE 40 U RAZINI GIPS ZIDA (str.8) ŽBUKA (str.12) - POVLAČENJE</p> <p>FI SYNTESIS® BATTENTE 40-SARANAOVEN ASENNUS LEVYRAKENTEINEN SEINÄ (sivu 8) KIVISEINÄ (sivu 12) - VEDÄ</p> <p>TR SYNTESIS® BATTENTE 40 ÇERÇEVE KİTİ MENTEŞELİ ALÇI PANEL MONTAJI (sayfa 8) SIVAMA (sayfa 12) - ÇEKİNİZ</p> <p>LT</p> |
|-----------------------------------------------------------------------------------------------------------------------------------------------------------------------------------------------------------------------------------------------------------------------------------------------------------------------------------------------------------------------------------------------------------------------------------------------------------------------------------------------------------------------------------------------------------------------------------------------------------------------------------------------------------------------------------------------------------------------------------------------------------------------------------------------------------------------------------------------------------------------------------------------------------------------------------------------------------------------------------------------------------------------------------------------------------------------------------------------------------------------------------------------------------------------------------------------------------------------------------------------------------------------------------------------------------------------------------------------------------|--------------------------------------------------------------------------------------------------------------------------------------------------------------------------------------------------------------------------------------------------------------------------------------------------------------------------------------------------------------------------------------------------------------------------------------------------------------------------------------------------------------------------------------------------------------------------------------------------------------------------------------------------------------------------------------------------------------------------------------------------------------------------------------------------------------------------------------------------------------------------------------------------------------------------------------------------------------------------------------------------------------------------------------------------------------------------------------------------------------------------------------------------------------------------------------|

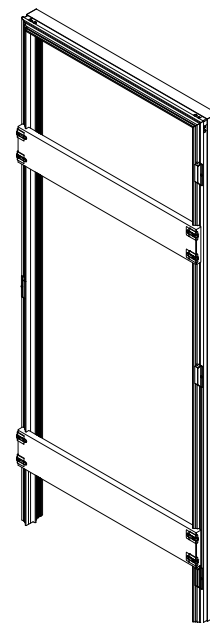

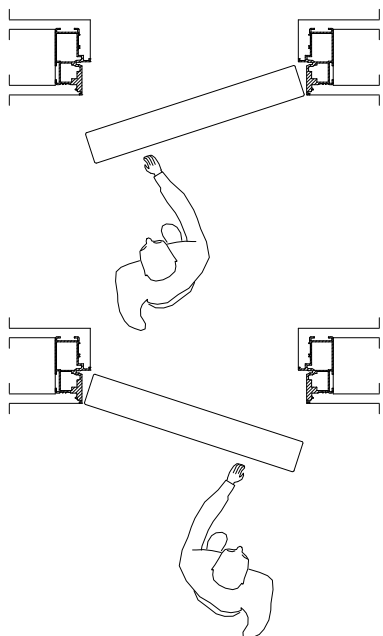

IT Seguire attentamente le istruzioni.
Per un corretto montaggio, utilizzare utensili adatti come indicato e, per una corretta ergonomia, eseguire gli assemblaggi su supporti adeguati.
Alcune parti dei componenti possono avere delle superfici appuntite.
E' necessario quindi utilizzare adeguati dispositivi di protezione e proteggere le zone di lavoro.
"ECLISSE srl", non si assume alcuna responsabilità per danni derivati dall'uso non conforme alle presenti istruzioni.

Tutti i componenti del controtelaio sono testati e controllati in "ECLISSE srl"

GB If you follow carefully these instructions for the assembly and installation process your life will be easier!
A pair of tressles are very useful when assembling the frames.
Some parts may have sharp edges so use gloves and be careful when handling the parts.

All Eclisse products are fully inspected and tested before they leave the factory.

BR Seguir atentamente as instruções.
Para uma instalação correta, utilize ferramentas apropriadas conforme as instruções e, para uma ergonomia adequada, efetue as instalações utilizando suportes adequados. Algumas partes dos componentes podem ter superfícies cortantes, portanto é necessária a utilização de equipamentos de proteção adequados e é preciso proteger as áreas destinadas à execução dos trabalhos.
PT "ECLISSE srl", não assume qualquer responsabilidade por danos resultantes da utilização e execução que não estejam de acordo com estas instruções.

Todos os componentes do caixilho/sistema embutido são testados e controlados na "Eclisse srl"

CZ Postupujte pozorně dle pokynů.
Pro správnou instalaci používejte vhodné nástroje a s ohledem na bezpečnost práce používejte vhodné pracovní pomůcky. Některé vyrobené části mohou obsahovat ostré prvky. Proto je nutné používat odpovídající ochranné pomůcky a chránit pracovní místa. "ECLISSE srl" neodpovídá za žádné škody vyplývající z nedodržení návodu na montáž.

Všechny komponenty stavební záručně jsou testovány a kontrolovány v "ECLISSE srl".

SK Dôsledne dodržiavajte návod na montáž.
Pri montáži používajte uvedené náradie.
Kvôli správnej ergonomii a bezpečnosti pri práci odporúčame použiť montážne podpery.
Niektoré diely môžu mať ostré hrany.
Používajte ochranné pracovné prostriedky.
„ECLISSE srl.“ nezodpovedá za škody spôsobené nedodržaním návodu na montáž.

Všetky komponenty puzdra sú testované a kontrolované v „ECLISSE srl.“.

ES Seguir las instrucciones con atención.
Para un montaje correcto, utilizar las herramientas indicadas, y para una correcta funcionalidad, ensamblar en los soportes adecuados.
Algunas partes del producto pueden contener superficies punzantes y/o cortantes.
Se necesita utilizar dispositivos de protección adecuados y proteger los espacios de trabajo.
"Eclisse SRL" no asume responsabilidad alguna por los daños derivados en la utilización no conforme a estas instrucciones.

Todos los componentes del contramarco están testados y controlados en "ECLISSE SRL".

NL Volg u deze instructies nauwkeurig.
Gebruik voor een correcte montage geschikt gereedschap, zoals aangeraden.
Voor een correcte werkhouding adviseren wij met schragen te werken.
Sommige delen van de verschillende onderdelen kunnen scherpe kanten hebben, daarom is het noodzakelijk om de juiste bescherming te dragen en de werkruimte te beschermen.
"ECLISSE srl" is niet aansprakelijk voor schade die ontstaan is door het niet opvolgen van deze instructies.

Allle delen van het frame zijn volledig geïnspecteerd en getest door "ECLISSE srl".

FR Suivre scrupuleusement les instructions
Afin de réaliser un assemblage correct, choisir un support adapté et utiliser les outils appropriés comme indiqué sur la notice.
Quelques éléments du produit peuvent avoir des parties pointues ou coupantes, il est donc nécessaire d'utiliser des protections corporelles efficaces et sécuriser l'espace de montage.
ECLISSE décline toute responsabilité pour tous dommages provoqués par le non respect de ces règles.

Tous les composants du produit sont testés et vérifiés par ECLISSE SRL.

DE Folgen Sie genau der Montageanleitung
Für die korrekte Montage, verwenden Sie die angegebenen passenden Werkzeuge. Für die korrekte Ergonomie, sollten die Montagearbeiten auf passende Arbeitsflächen ausgeführt werden.
Einige der Bauteile können spitze Oberflächen haben. Es ist notwendig passende Schutzvorrichtungen zu verwenden und die Arbeitsfläche schützen.
„Eclisse Srl“ übernimmt keine Verantwortung für Beschädigungen, die durch Nichtbeachtung der Montageanleitung hervorgerufen werden.
Wandöffnung nach DIN 18183-1 erstellen
Alle Bauteile des Einbaukastens wurden in „Eclisse“ geprüft und getestet.

PL Postępować zgodnie z instrukcją montażu.
W celu wykonania prawidłowego montażu, używać odpowiednich narzędzi, zgodnych ze wskazaniami, a dla zapewnienia odpowiedniej ergonomii pracy przy dokonaniu montażu stosować odpowiednie podpory. Powierzchnia niektórych elementów składowych może być ostra. W związku z tym koniecznym jest stosowanie odpowiednich środków ochrony indywidualnej oraz zabezpieczenie obszaru pracy. Eclisse SRL uchyła się od poniesienia jakiegokolwiek odpowiedzialności za poniesione szkody wynikające z postępowania niezgodnego z późniejszą instrukcją.

Wszelkie części składowe asortymentu Eclisse SRL są testowane w wewnętrznym laboratorium.

RU Пожалуйста, строго следуйте инструкциям.
Для правильной установки пользоваться соответствующим оборудованием как указано, для правильной эргономики сделать монтаж на надежных основах. Некоторые части могут иметь заостренные концы, в связи с чем следует использоваться соответствующим предохранительным устройством и защитить рабочую зону.
«ECLISSE srl» не несет ответственности за ущерб, ставший следствием несоблюдения правил, содержащихся в данной инструкции.

Все компоненты пенала проходят необходимую проверку в фирме «ECLISSE srl».

RO Urmați cu atenție instrucțiunile de montaj.
Pentru un montaj corect, folosiți ustensile potrivite, iar pentru o ergonomie adecvată, asamblarea se face pe suporturi corespunzătoare, urmând metodele indicate. Unele părți ale componentelor pot avea suprafețe ascuțite.
Prin urmare, este necesar să se folosească echipamente de protecție și să se asigure zona de lucru.
ECLISSE EST SRL nu își asumă nici o responsabilitate pentru daunele survenite ca rezultat al nerespectării prezentelor instrucțiuni.

Toate componentele din structura cadrului metalic sunt testate și controlate în fabrică.

SI Če boste pazljivo prebrali in upoštevali dana navodila za sestavo in montažo podboja bo bistveno enostavneje.
Priporočljiva je uporaba rokavic zaradi morebitnih ostrih robov in previdno rokujte z izdelkom.

Vsi Eclisse izdelki so pod stalno kontrolo in testirani preden zapustijo tovarno.

HU Az összeszerelésnél figyelmesen kövesse a beépítési útmutatót!
Szerelőbak használata megkönnyíti az összeszerelést.
Az éles szélek sérülést okozhatnak, ezért használjon védőkesztyűt az összeszerelésnél.

Minden Eclisse termék minőségellenőrzésen esik át forgalomba kerülés előtt.

HR Pazljivo slijedite upute.
Za pravilnu montažu, koristite odgovarajuću alat kao što je navedeno, a za postizanje pravilnog ergonomskog položaja, montirajte dijelove na odgovarajuće nosače. Površine pojedinih sastavnih dijelova mogu biti zaoštrene. Stoga je potrebno koristiti odgovarajuću zaštitnu opremu i zaštititi područja rada.
"ECLISSE srl" ne preuzima nikakvu odgovornost za štete prouzročene korištenjem koje nije u skladu s ovim uputama.

Svi sastavni dijelovi okova za vrata su ispitani i provjereni u "ECLISSE srl"

FI Noudata näitä kokoamis- ja asennusohjeita tarkasti.
Kehysten kokoamisessa kannattaa käyttää apuna pukkeja.
Käytä suojakäsineitä, sillä osien reunat voivat olla teräviä.

Kaikki Eclisse-tuotteet tarkastetaan ja testataan tehtaalla ennen toimittamista.

TR Eğer bu talimatları dikkatle takip ederseniz, montaj ve kurulum için işiniz daha kolay olacaktır.
Çerçevenin montajını yaparken, bir çift kasanın kullanılması çok faydalı olur. Bazı parçalar keskin kenarlara sahip olabilir, bu nedenle eldiven kullanılmalı ve parçaları tutarken daha dikkatli olunmalıdır.

Eclisse'nin tüm ürünleri fabrika çıkışından önce kontrol edildi ve test edildi.

LT Jeigu tiksliai vadovausitės šiomis surinkimo ir montavimo instrukcijomis, jūsų gyvenimas bus lengvesnis. Staktą surinkite ant tinkamo pagrindo. Kai kurios staktos dalys gali būti aštrios, tad mūvėkite pirštines ir būkite atsargūs keldami staktą ar jos dalis.

Vsi Srl Eclisse gaminiai yra visiškai išbandyti ir patikrinti.

ATTREZZATURA NECESSARIA PER IL MONTAGGIO / TOOLS REQUIRED / EQUIPAMENTOS / NECESSÁRIOS PARA A MONTAGEM /
 NÁŘADÍ POTŘEBNÉ K MONTÁŽI / NÁRADIE POTREBNÉ NA MONTÁŽ / HERRAMIENTAS NECESARIAS PARA EL MONTAJE /
 BENODIGD GEREEDSCHAP / OUTILS NECESSAIRES POUR L'ASSEMBLAGE / NOTWENDIGES WERKZEUG ZUR AUSFÜHRUNG DER
 MONTAGE / OPRZYRZĄDOWANIE POTRZEBNE DO MONTAŻU / НОЕОБХОДИМОЕ ДЛЯ УСТАНОВКИ ОБОРУДОВАНИЕ /
 ECHIPAMENTE NECESARE PENTRU MONTAJ / PRIPOROČLJIVO ORODJE / SZÜKSÉGES ESZKÖZÖK / ALAT POTREBAN ZA MONTAŽU
 / TARVITAVAT VÄLINEET / GEREKLİ ARAÇLAR / SURINKIMUI IR MONTAVIMUI REIKALINGI ĮRANKIAI

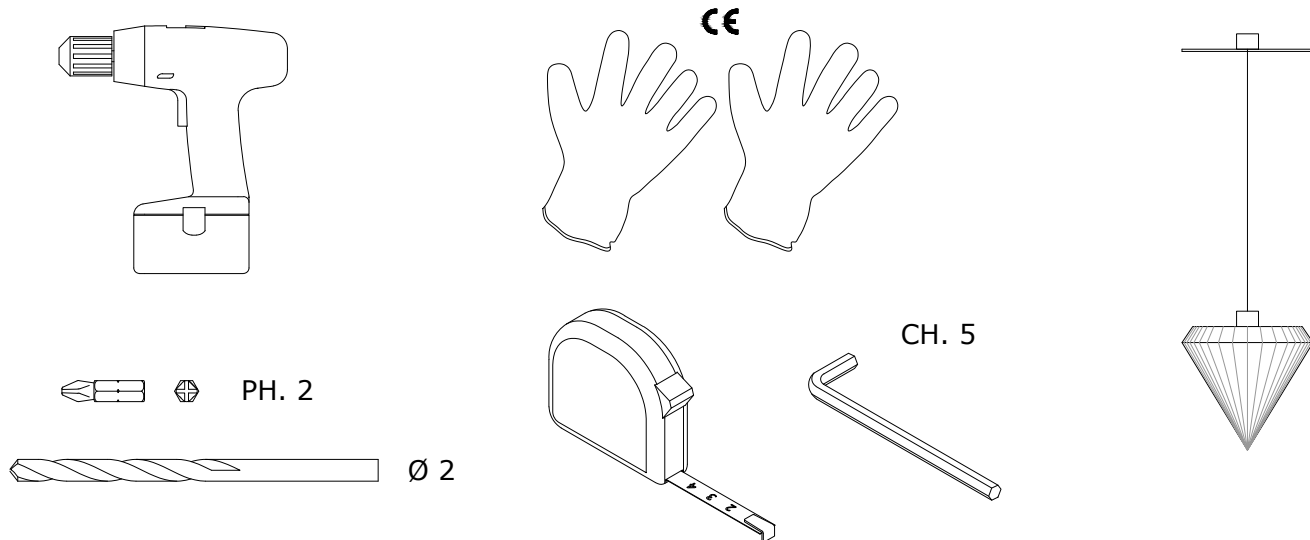

COMPONENTI / COMPONENTS / COMPONENTES / KOMPONENTY / KOMPONENTY /
 COMPONENTES / ONDERDELEN / COMPOSANTS / BAUTEILE / CZĘŚCI / КОМПОНЕНТЫ /
 COMPONENTE / SESTAVNI DELI / ALKATRÉSZEK / SASTAVNI DIJELOVI / OSAT / BİLEŞENLER /
 KOMPONENTAI

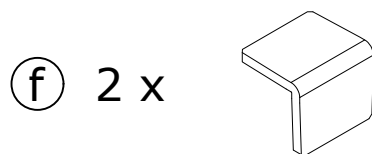
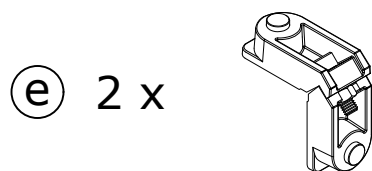
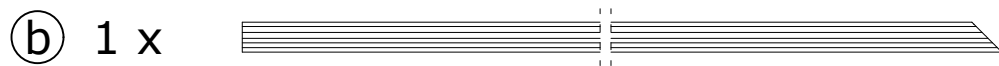
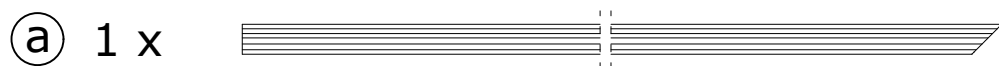

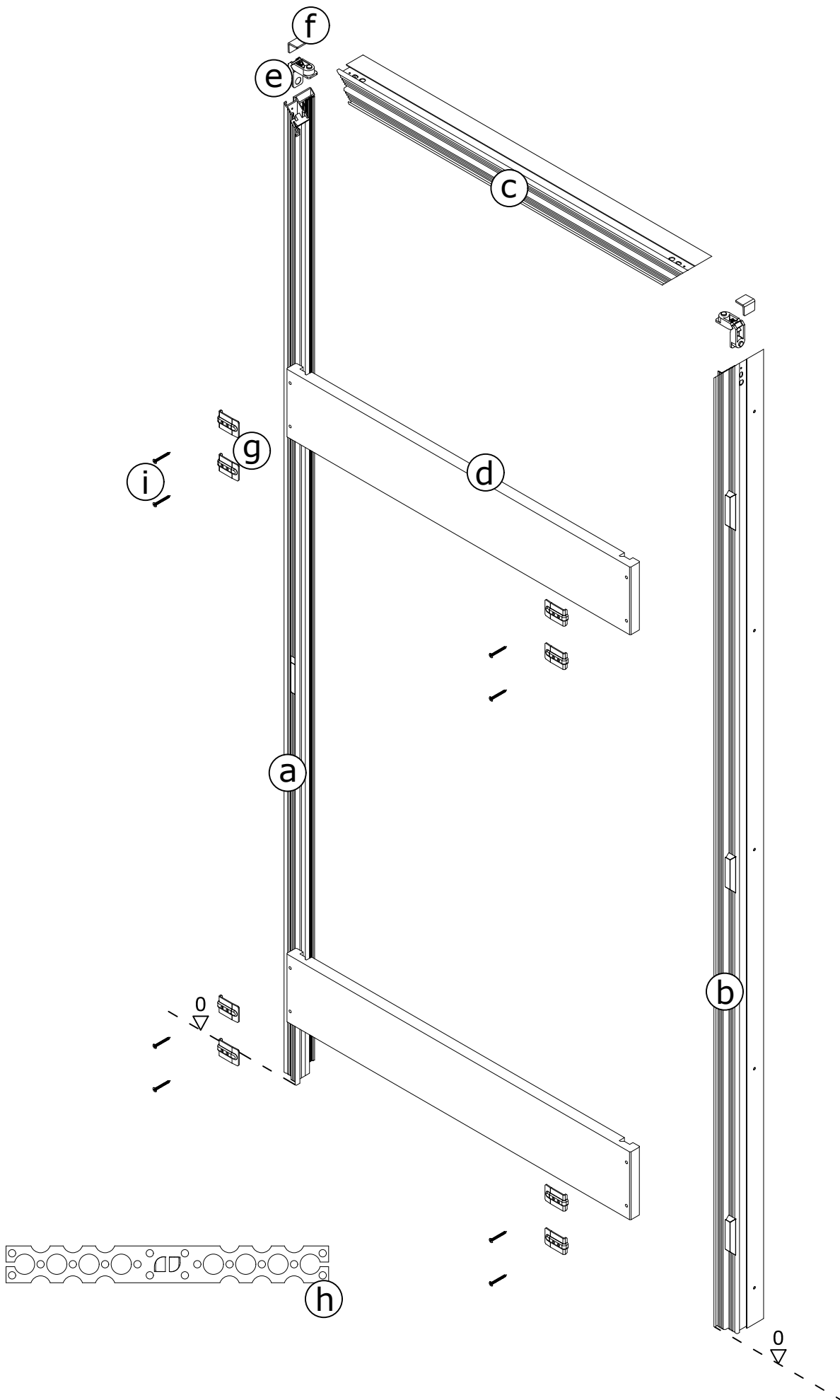

1

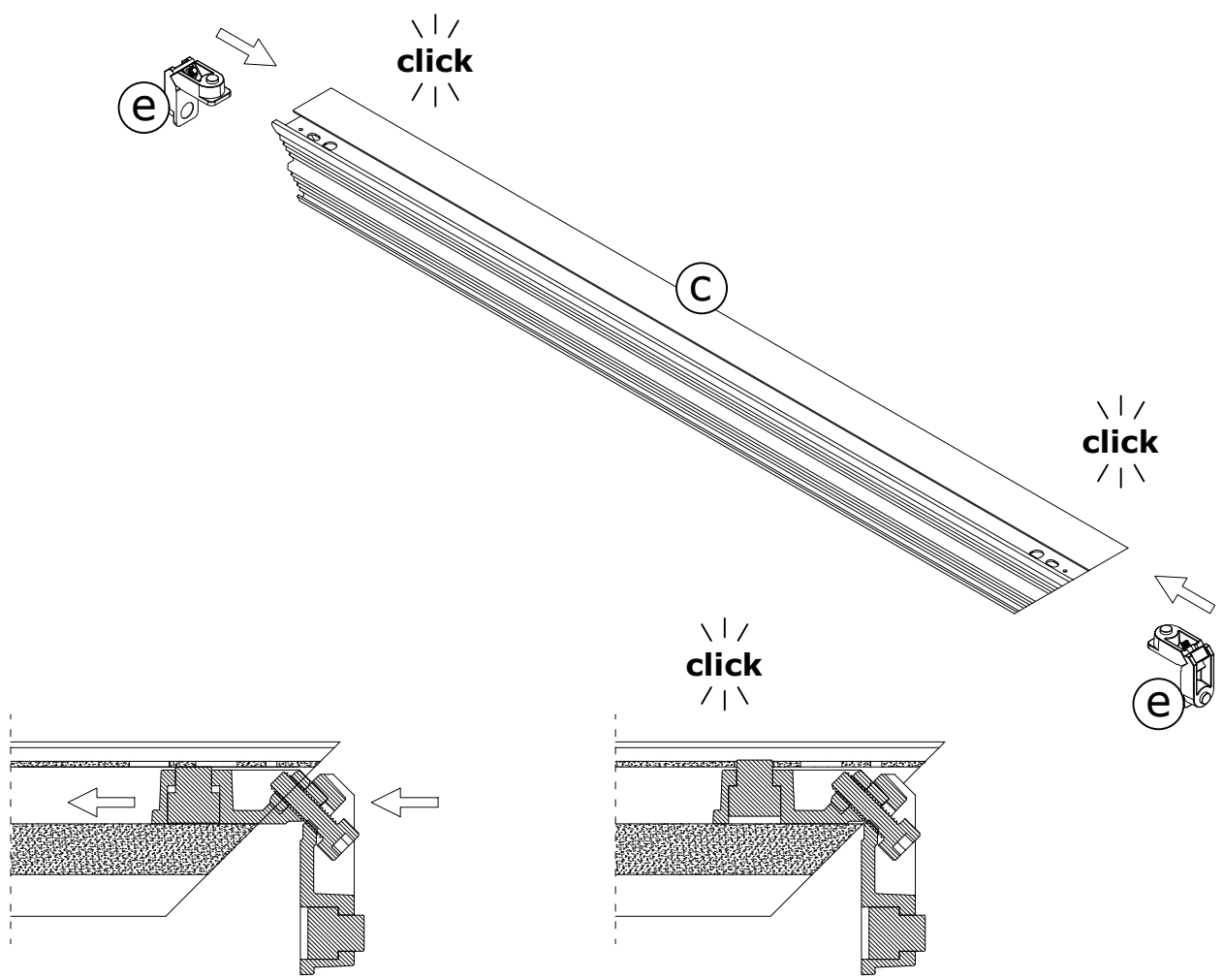

2

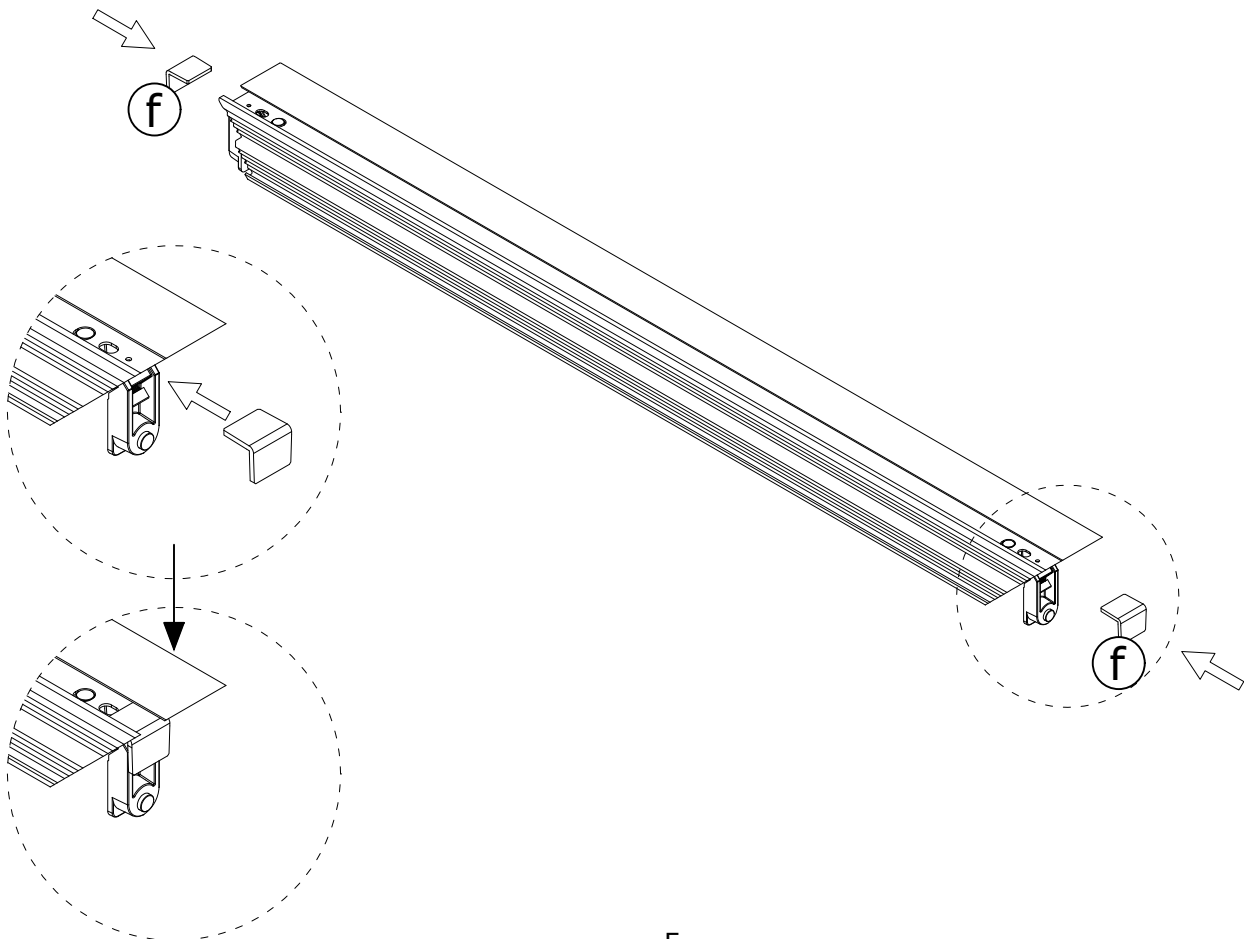

3

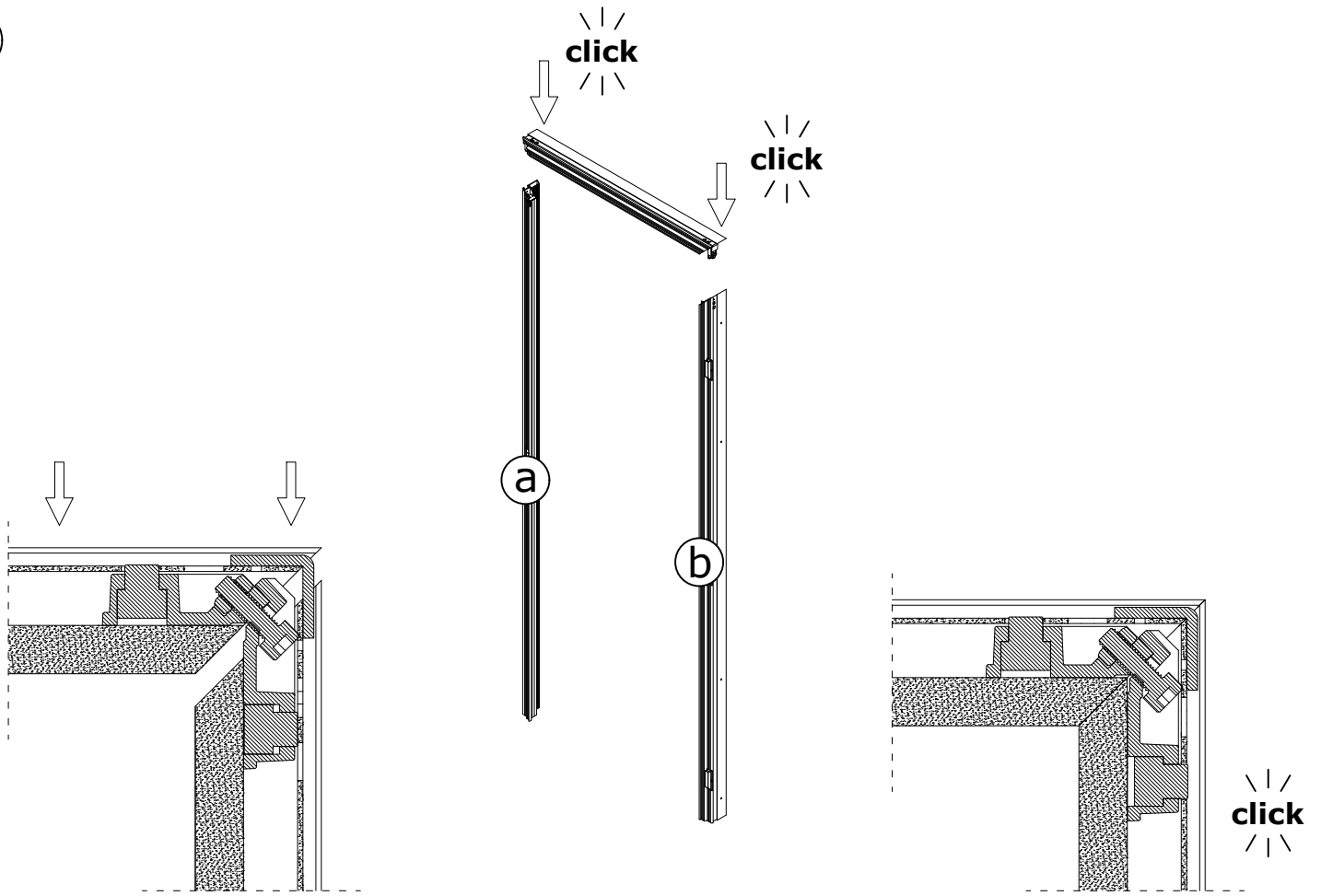

4

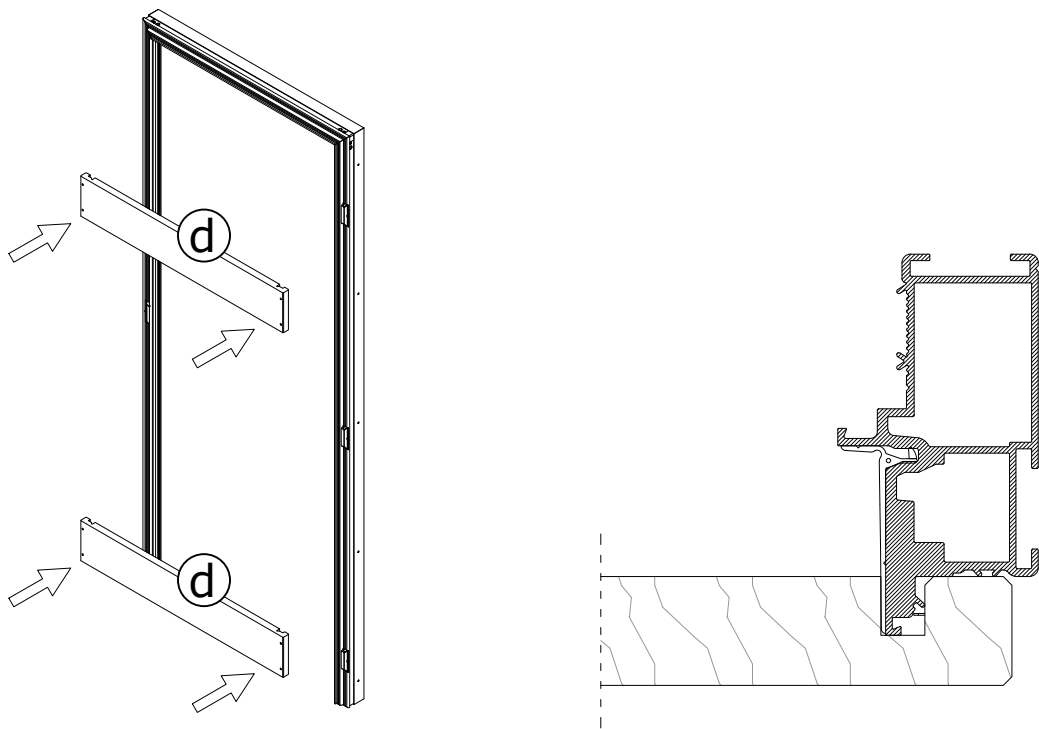

5

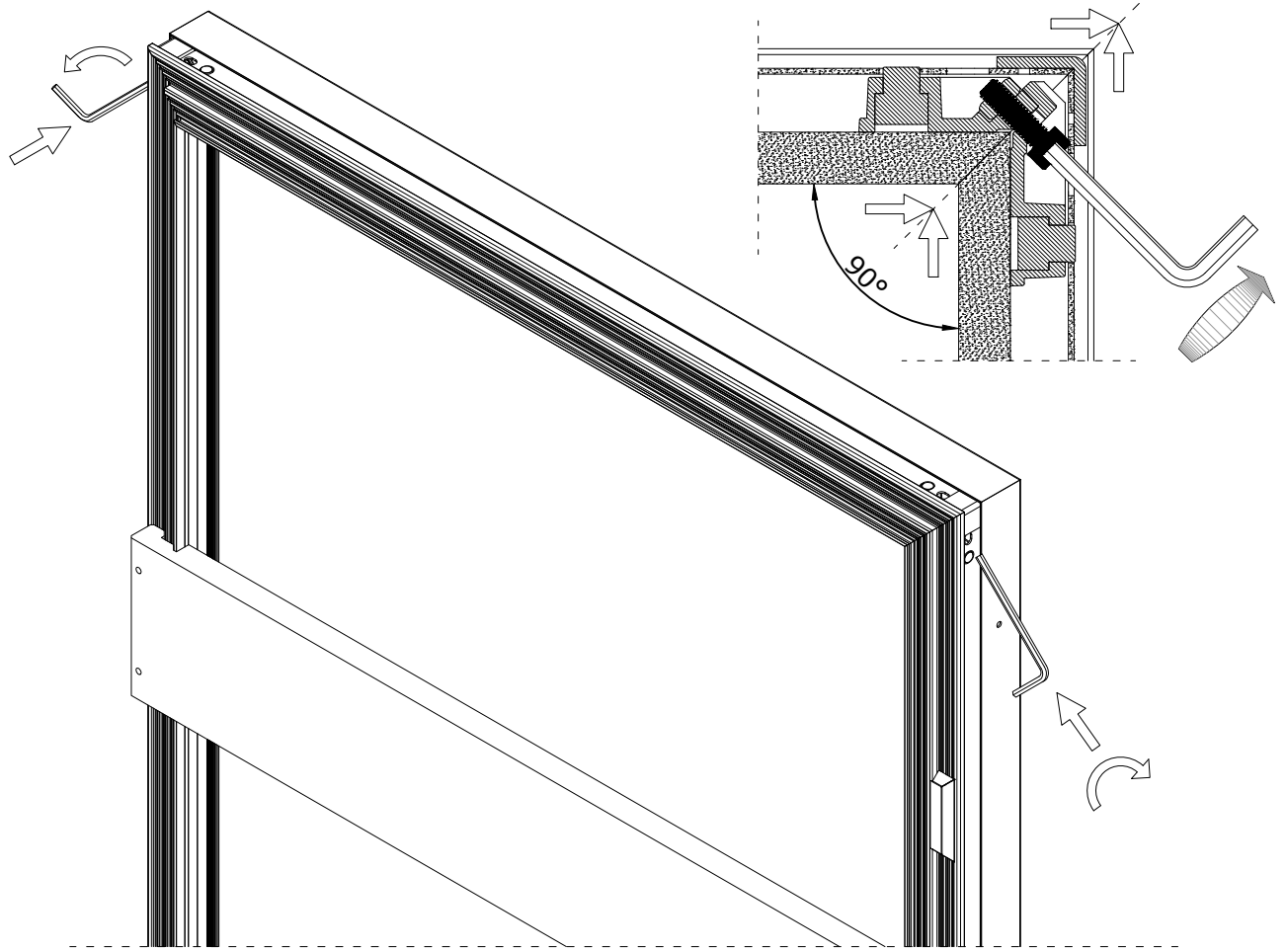

6

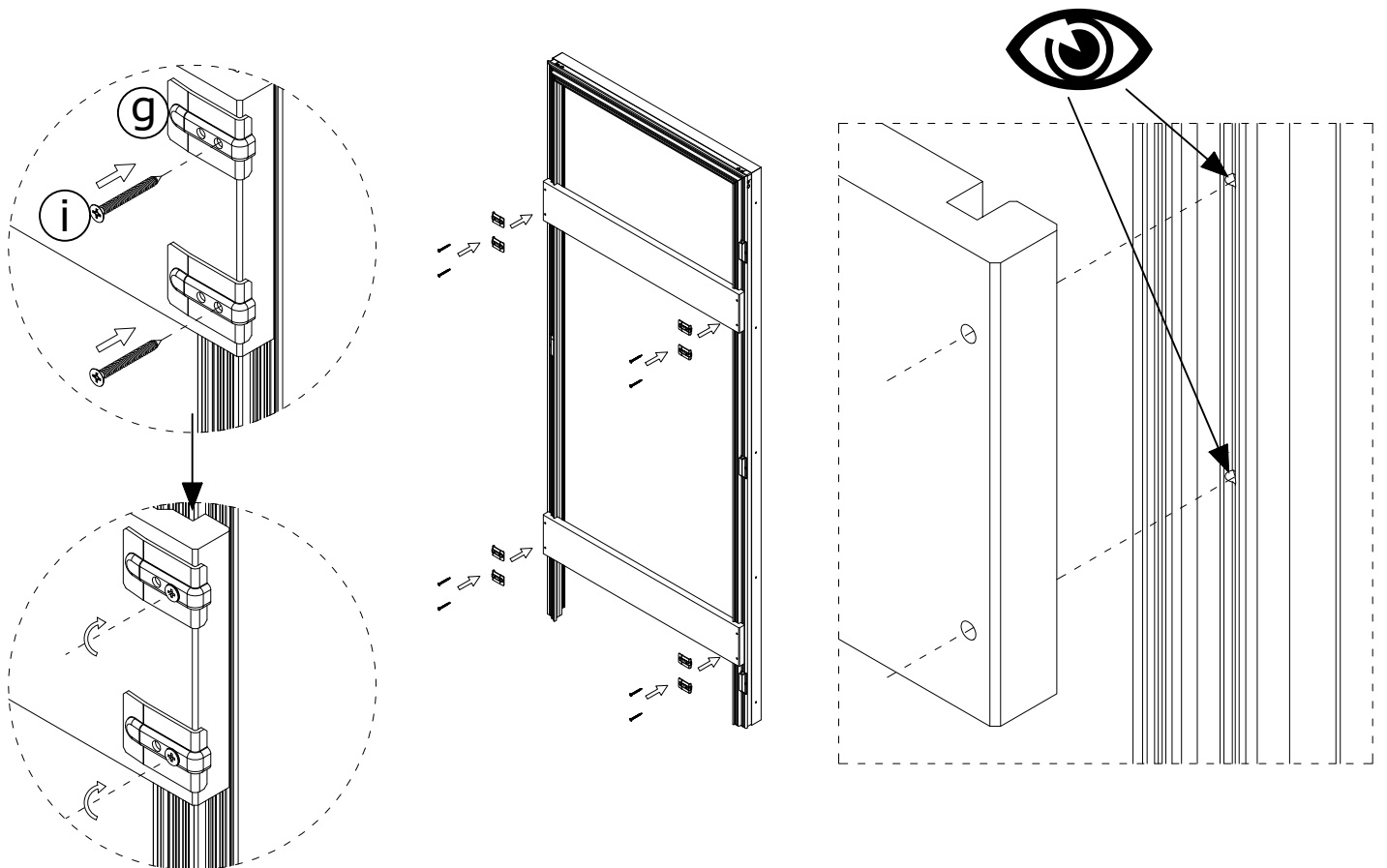

1 c IT **Cartongesso**

GB **Stud wall**

PT **Placa de gesso cartonado**

CZ **Sádrokarton**

SK **Sadrokartón**

ES **Cartón-yeso**

NL **Gipsplaat**

FR **Plaque de plâtre**

DE **Gipskarton**

PL **Ściana gips-karton**

RU **Гипсокартон**

RO **Gips carton**

SI **Mavčni karton**

HU **Gipszkarton**

HR **Gips zid**

FI **Levyrakenteinen seinä**

TR **Alçı Panel**

LT **Gipso kartono siena**

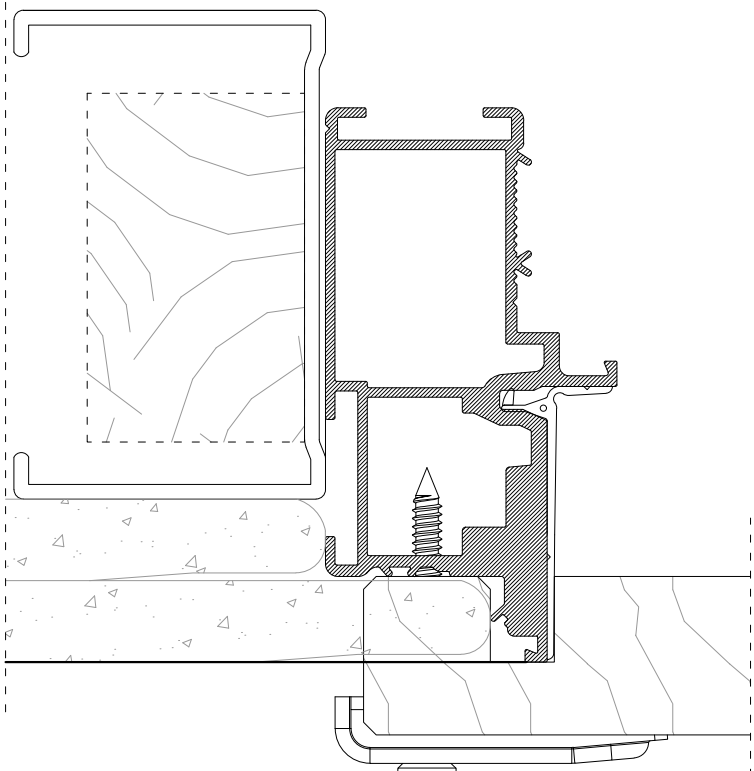
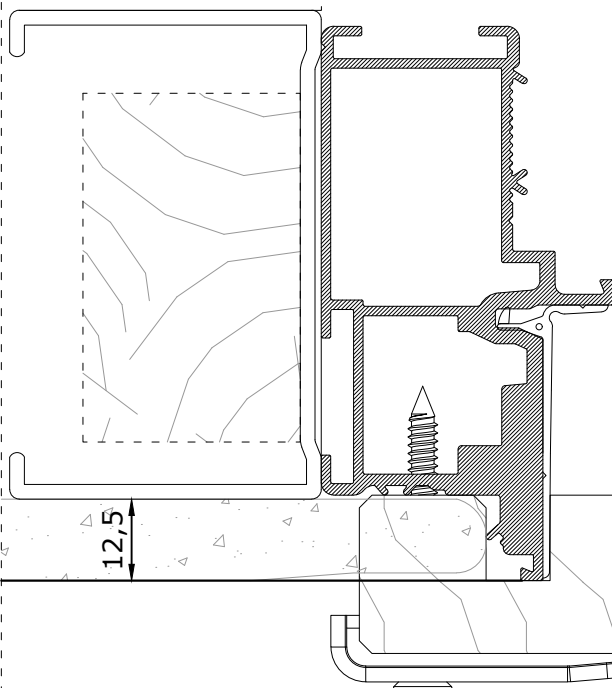
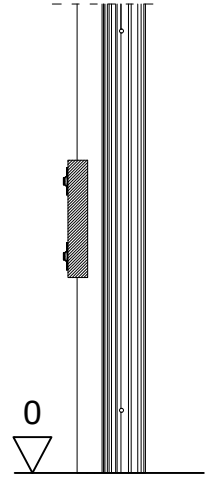
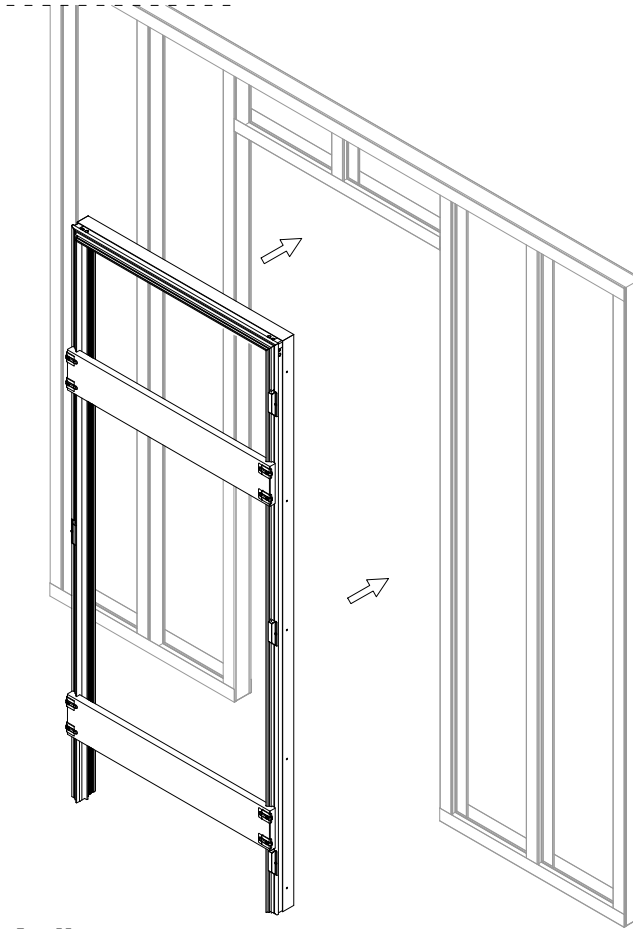
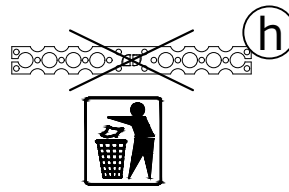

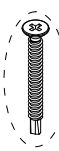
2 c

- IT PEZZO NON FORNITO
- GB NOT SUPPLIED
- PT ARTIGO NÃO INCLUIDO
- CZ NENÍ SOUČÁSTÍ BALENÍ
- SK NIE JE SÚČASŤOU BALENIA
- ES PIEZA NO SUMINISTRADA
- NL NIET BIJGESLOTEN
- FR PIÈCE NON FOURNIE
- DE NICHT IM LIEFERUMFANG
- PL CZĘŚĆ NIE ZABUDOWANE
- RU ДЕТАЛЬ НЕ ПОСТАВЛЯЕТСЯ
- RO PIESĂ NEFURNIZATĂ
- SI NI DOBAVLJENO
- HU NEM TARTOZÉK
- HR DIO KOJI NIJE DOSTAVLJEN
- FI TOIMITUKSEEN SISÄLTYMÄTTÖMÄT OSAT
- TR KUTU İÇİNDE YOKTUR
- LT NEĮSKAICIUOTA Į KOMPLEKTĄ

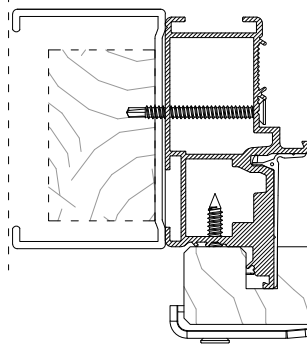

90°

90°

90°

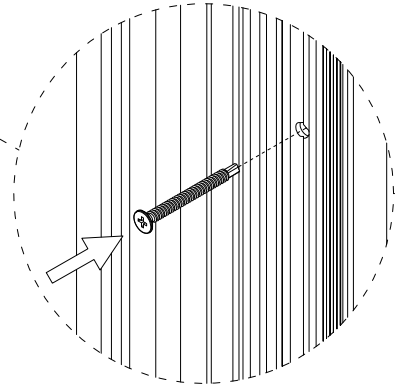
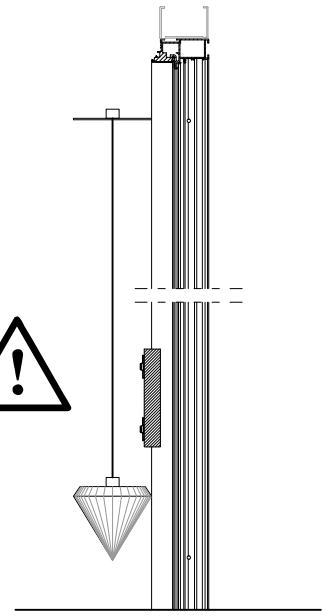
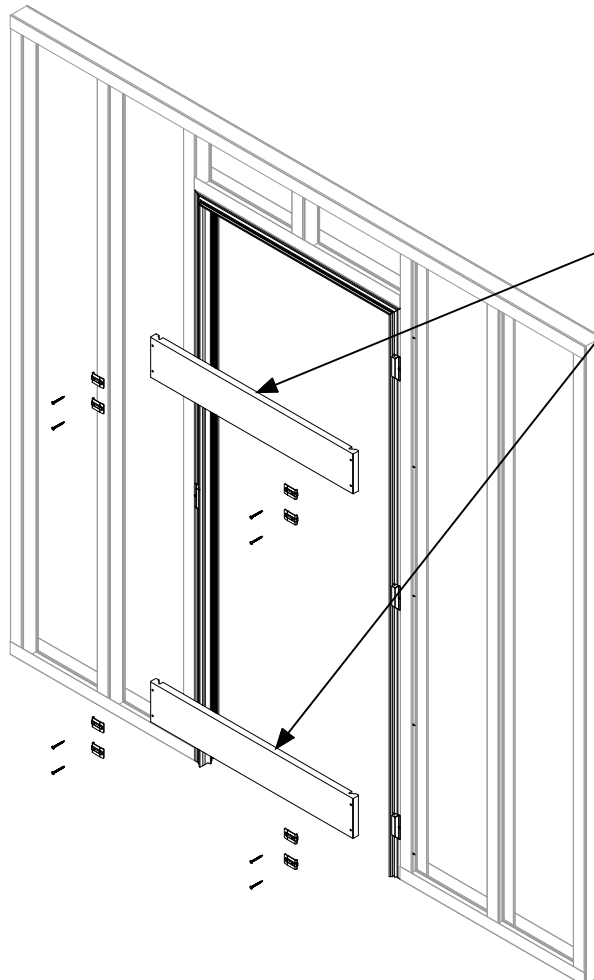
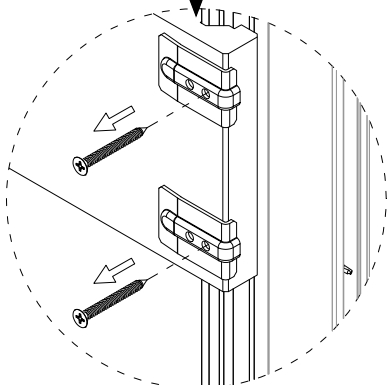
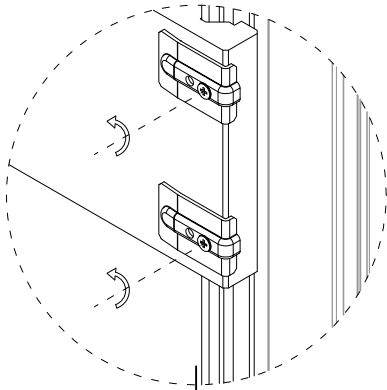
**3 c**

- IT TOGLIERE SOLO DOPO IL COMPLETO ANCORAGGIO
- GB ONLY REMOVE AFTER FIXING IS COMPLETE
- PT REMOVER SOMENTE APÓS A COMPLETA FIXAÇÃO
- CZ ODSTRÁŇTE AŽ PO ÚPLNÉM UKOTVENÍ
- SK ODSTRÁŇTE AŽ PO ÚPLNOM UKOTVENÍ
- ES REMOVER SOLO DESPUÉS DEL COMPLETO ANCLAJE
- NL PAS VERWIJDEREN NA VOLLEDIGE BEVESTIGING
- FR ENLEVER SEULEMENT APRÈS SÉCHAGE DES ANCRAGES
- DE ERST NACH KOMPLETTER VERANKERUNG ENTFERNEN
- PL USUNĄĆ PO CAŁKOWITYM MONTAŻU OŚCIEŻNICY
- RU СНЯТЬ ТОЛЬКО ПОСЛЕ ПОЛНОГО АНКЕРНОГО ЗАКРЕПЛЕНИЯ
- RO ÎNDEPĂRTAȚI DOAR DUPĂ ANCORAREA COMPLETĂ
- SI SNETI LE PO DOKONČANEM SIDRANJU
- HU CSAK A TELJES RÖGZÍTÉS UTÁN TÁVOLÍTSA EL
- HR UKLONITI SAMO NAKON POTPUNOG UČVRŠĆENJA
- FI POISTA VASTA KUN KIINNITYS ON VALMIS
- TR SADECE SABİTLEME TAMAMLANDIKTAN SONRA KALDIRINIZ
- LT DEMONTUOTI TIK STABILIAI ĮTVIRTINUS STAKTĄ

4 c

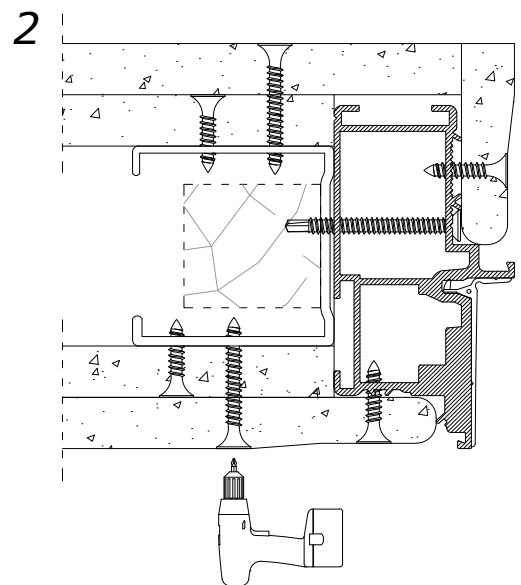
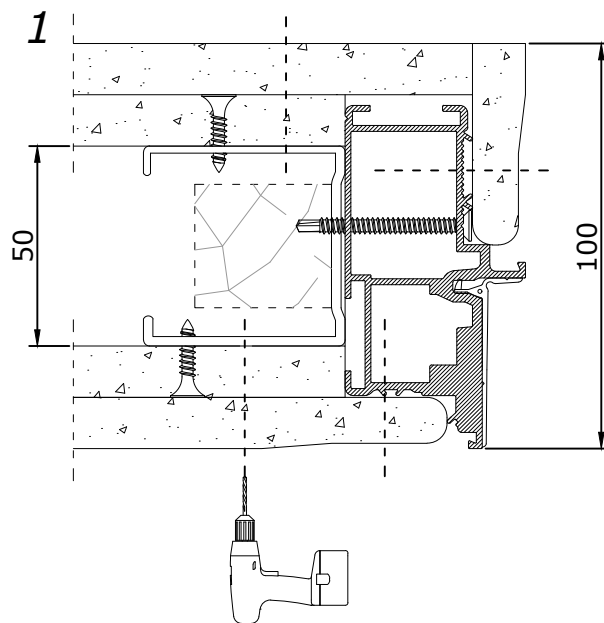
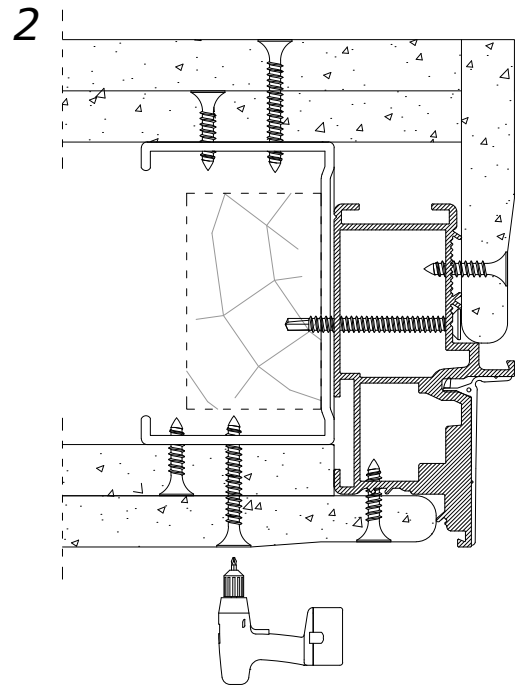
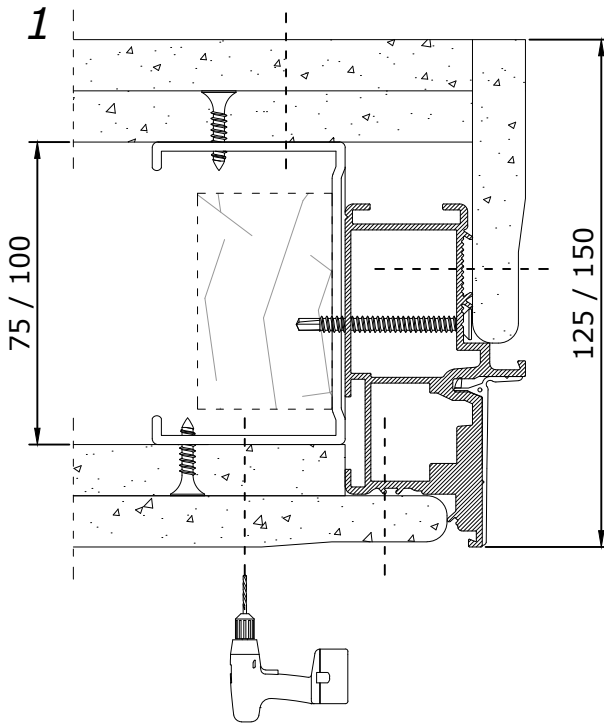
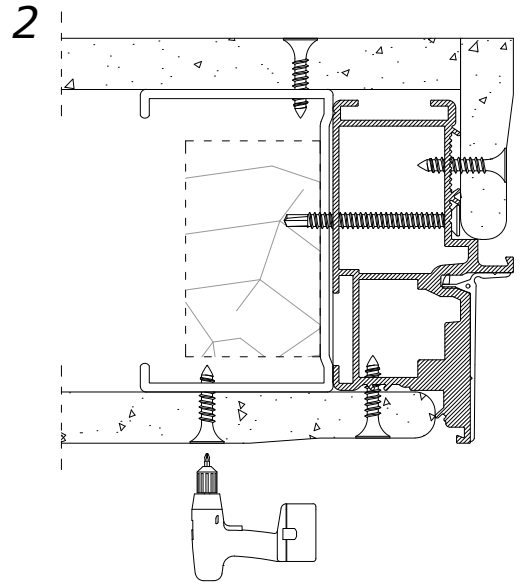
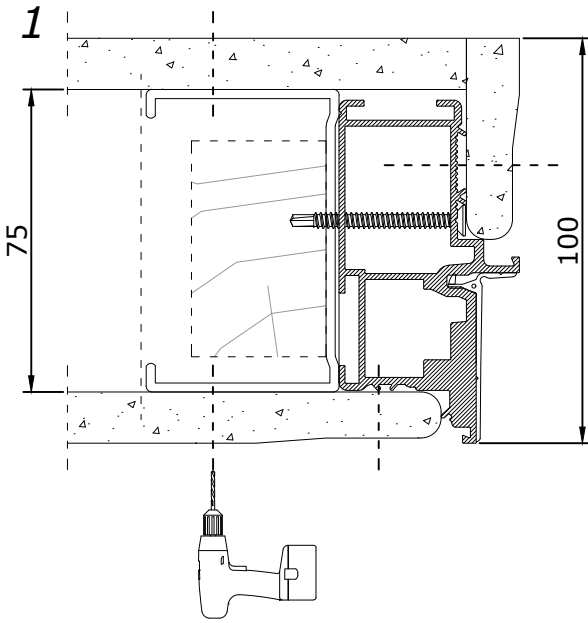
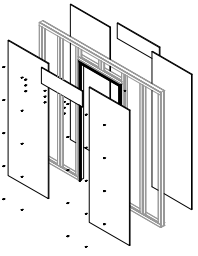

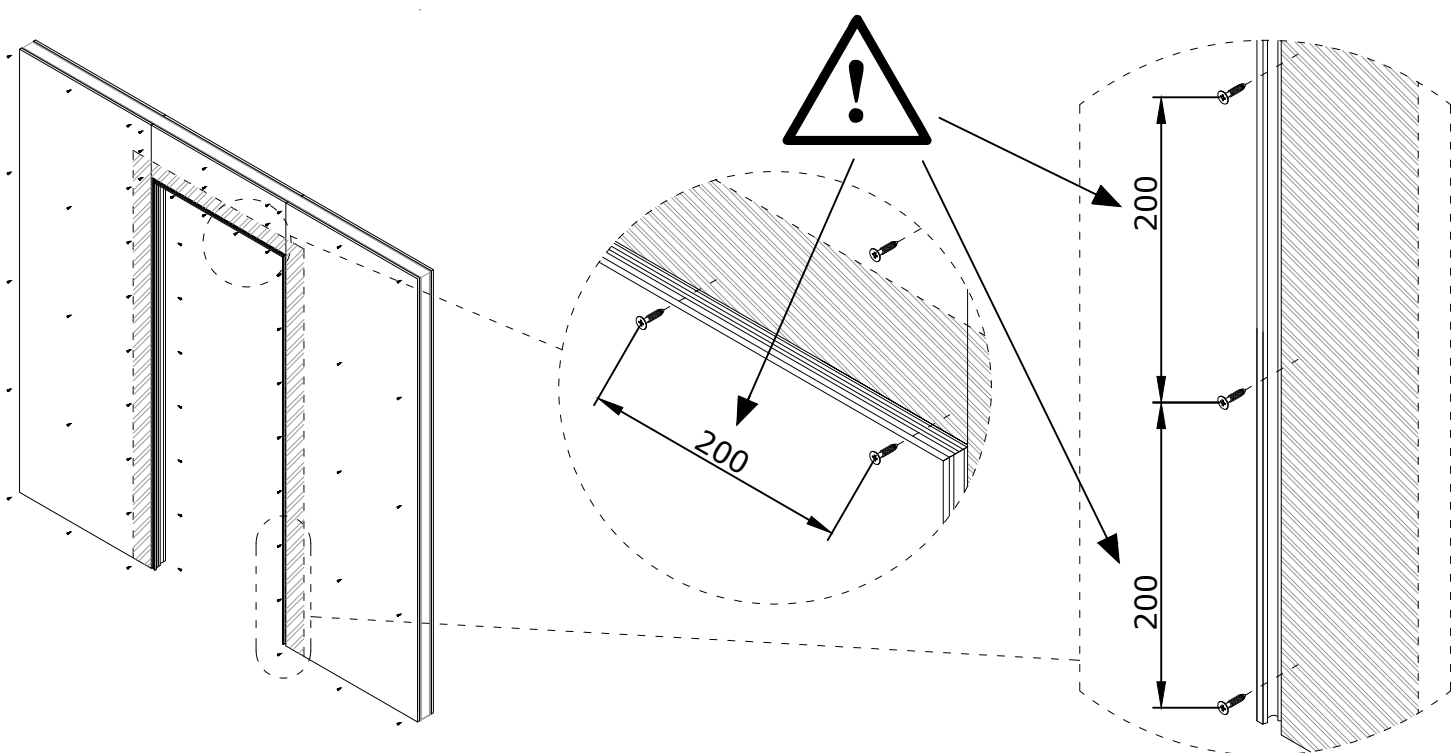

5 c

- Ⓘ APPLICATIONE STUCCO O SCAGLIOLA
- Ⓖ APPLICATION OF PLASTER OR SCAGLIOLA
- Ⓟ APLICAÇÃO DE ALVENARIA OU GESSO
- Ⓒ NANÁŠENÍ ŠTUKOVÉ OMÍTKY NEBO SÁDROKARTONOVÉHO TMELU
- Ⓚ NANÁŠANIE ŠTUKOVEJ OMIETKY ALEBO SADROKARTONÁRSKEHO TMELU
- Ⓔ APLICACIÓN DE ESTUCO O ESCAYOLA
- Ⓝ AANBRENGEN VAN PLAMUUR OF GIPS
- Ⓕ APPLICATION DE L'ENDUIT POUR PLAQUE DE PLÂTRE
- Ⓓ AUFBRINGUNG VON GIPS (BAUSEITZ)
- Ⓛ NAŁOŻENIE MASY GIPSOWEJ LUB TYNKU NA KRAWĘDZIE OŚCIEŻNICY
- Ⓡ НАНЕСЕНИЕ ШТУКАТУРКИ ДЛЯ ВНУТРЕННИХ ИЛИ НАРУЖНЫХ РАБОТ
- ⓇO APLICARE TENCUIALA SAU IPSOS
- ⓈI NANAŠANJE KITA ALI MAVCA
- ⒽU VAKOLAT VAGY SCAGLIOLA GIPSZMÁRVÁNY ALKALMAZÁSA
- ⒽR NANOŠENJE ŠTUKATURA ILI GIPSANOG PRAHA
- ⒻI TASOITUS- TAI RAPPAUSOHJE
- ⒹR SIVA UYGULAMASI
- ⒻT GLAISTYMAS

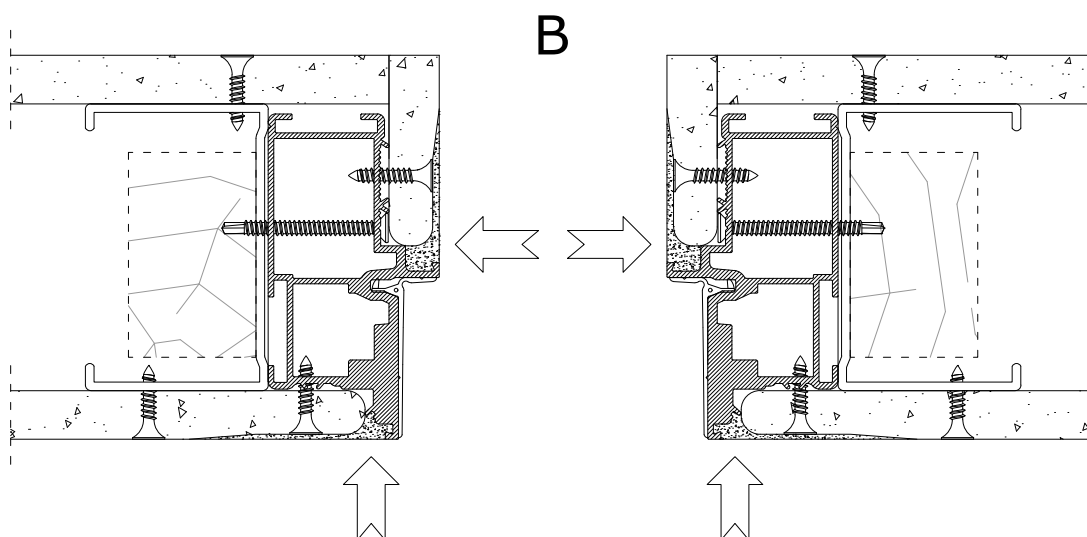
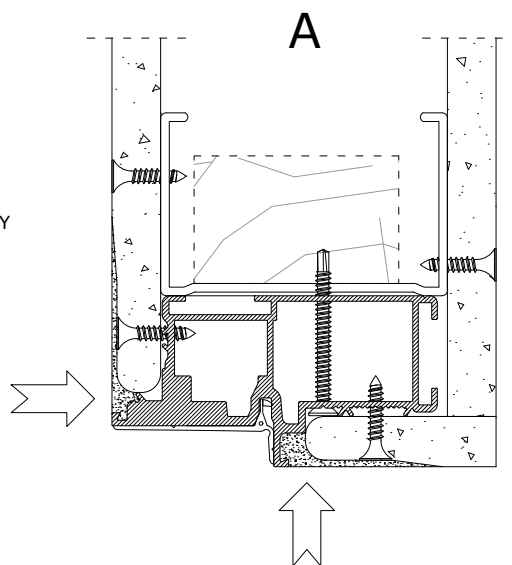
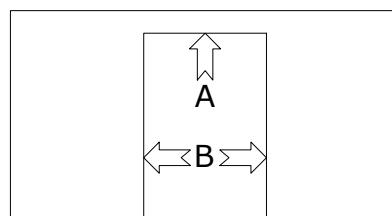

1 i IT Intonaco

GB Solid wall

PT Alvenaria

CZ Zdivo

SK Murivo

ES Enlucido

NL Pleisterwerk

FR Enduit

DE Verputz

PL Ściana murowana

RU Штукатурка

RO Tencuială

SI Omet

HU Vakolat

HR Žbuka

FI Kiviseinä

TR Sivama

LT Tinkuojama siena

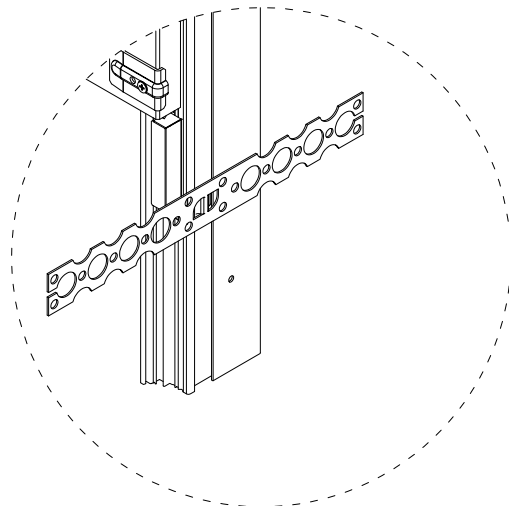
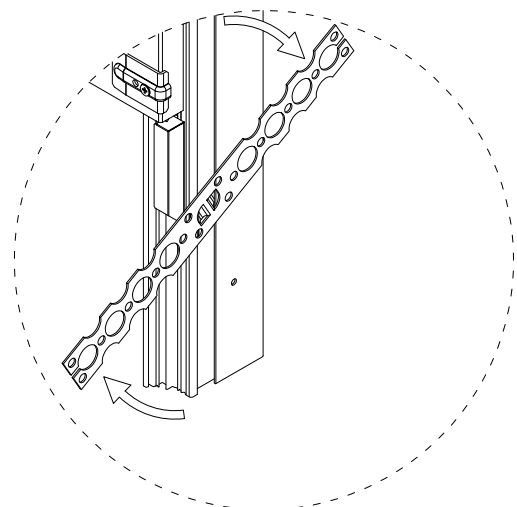
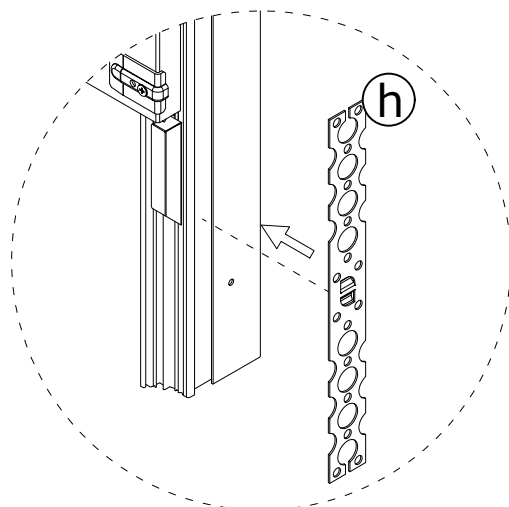
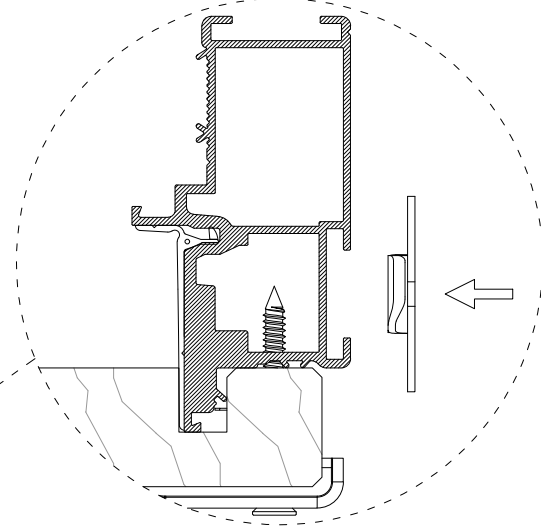
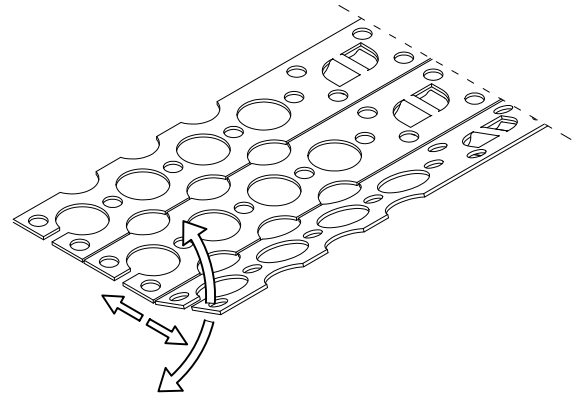
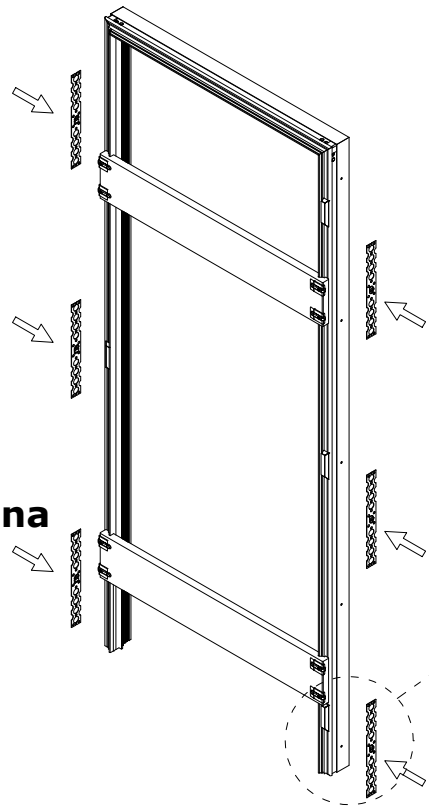

2 i

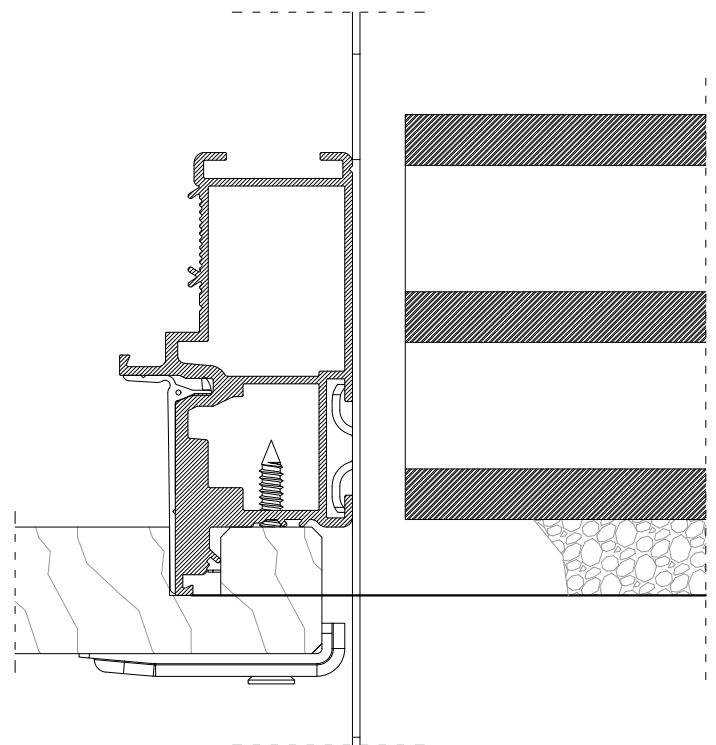
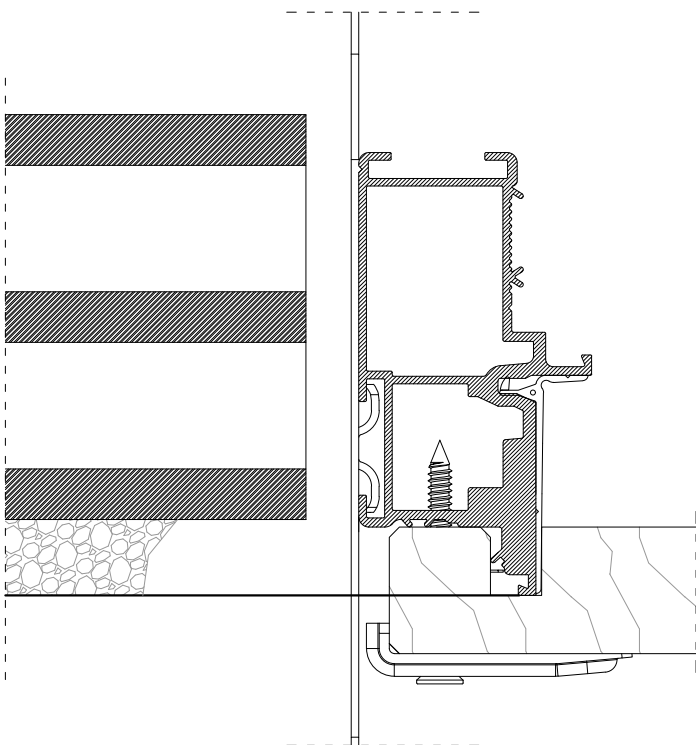
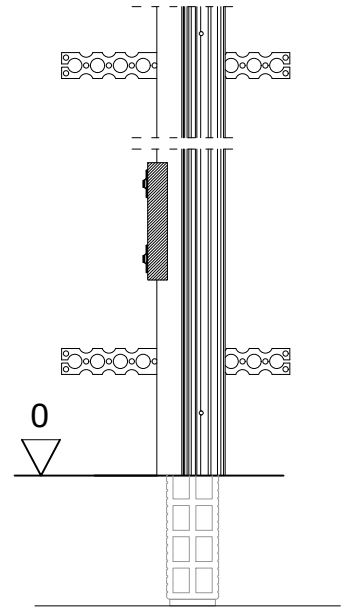
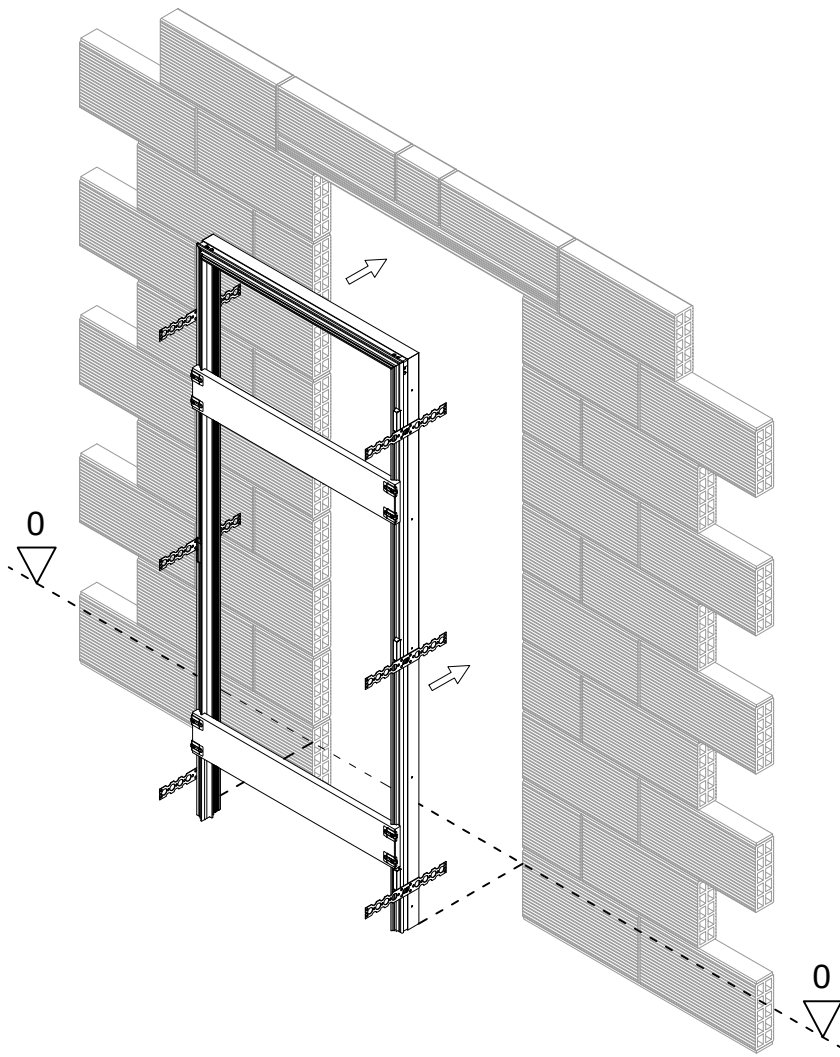

3 i

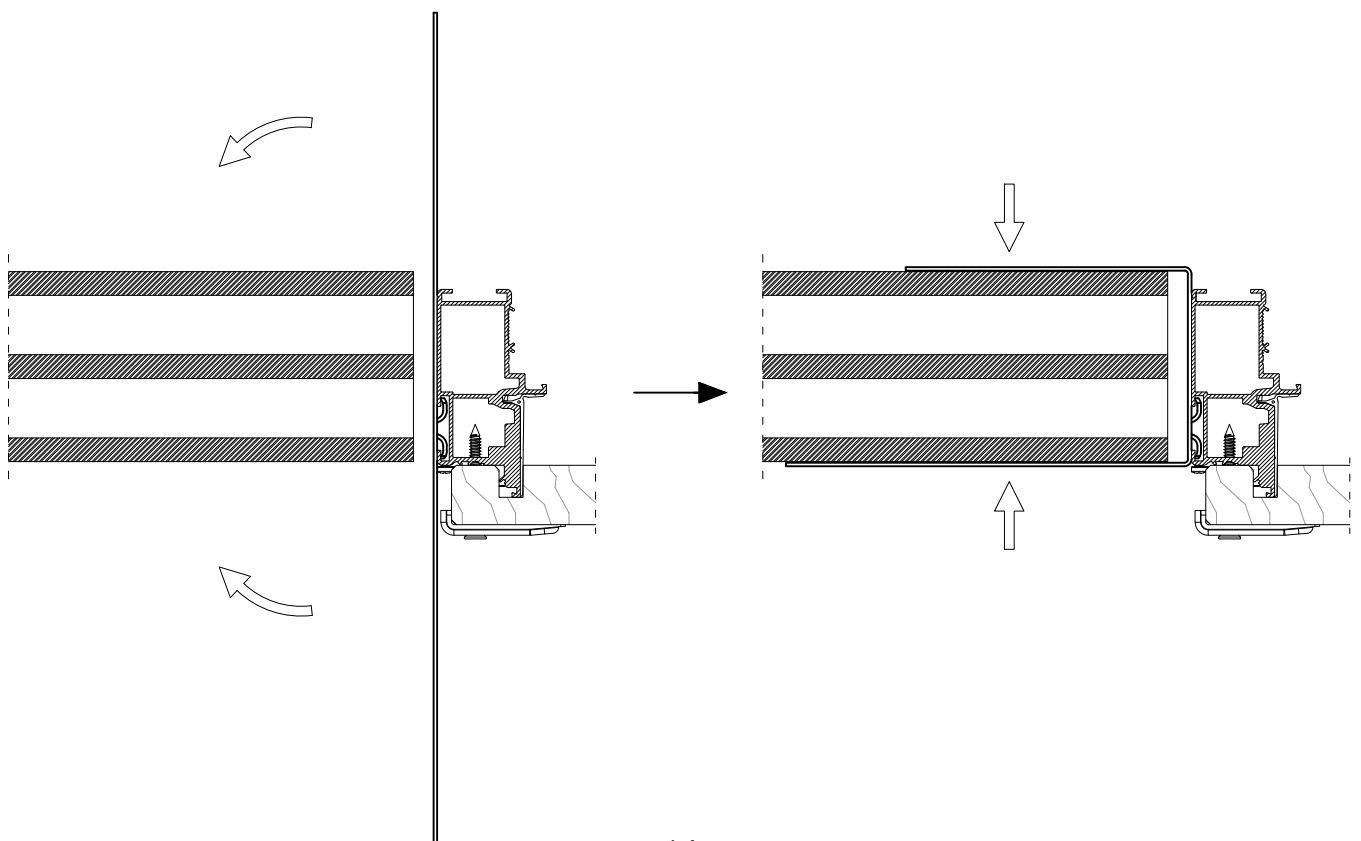
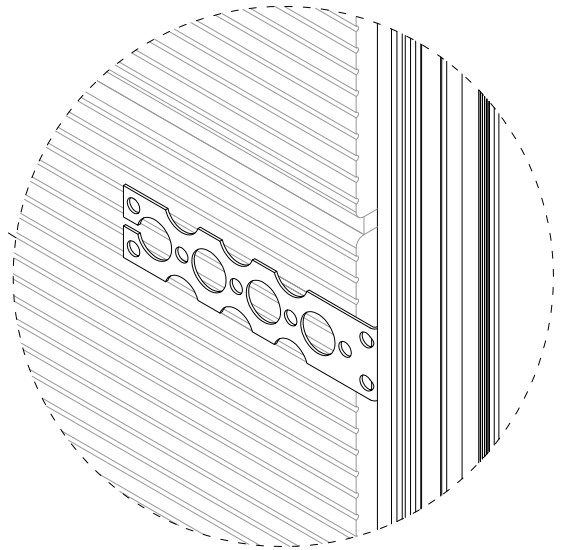
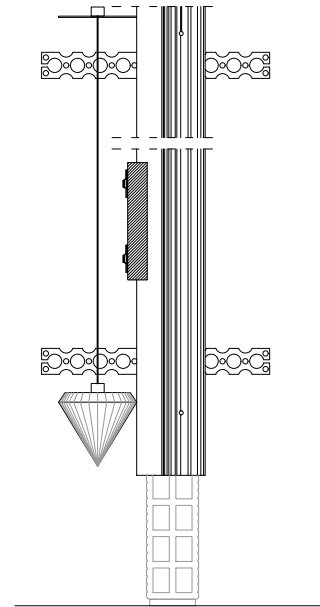
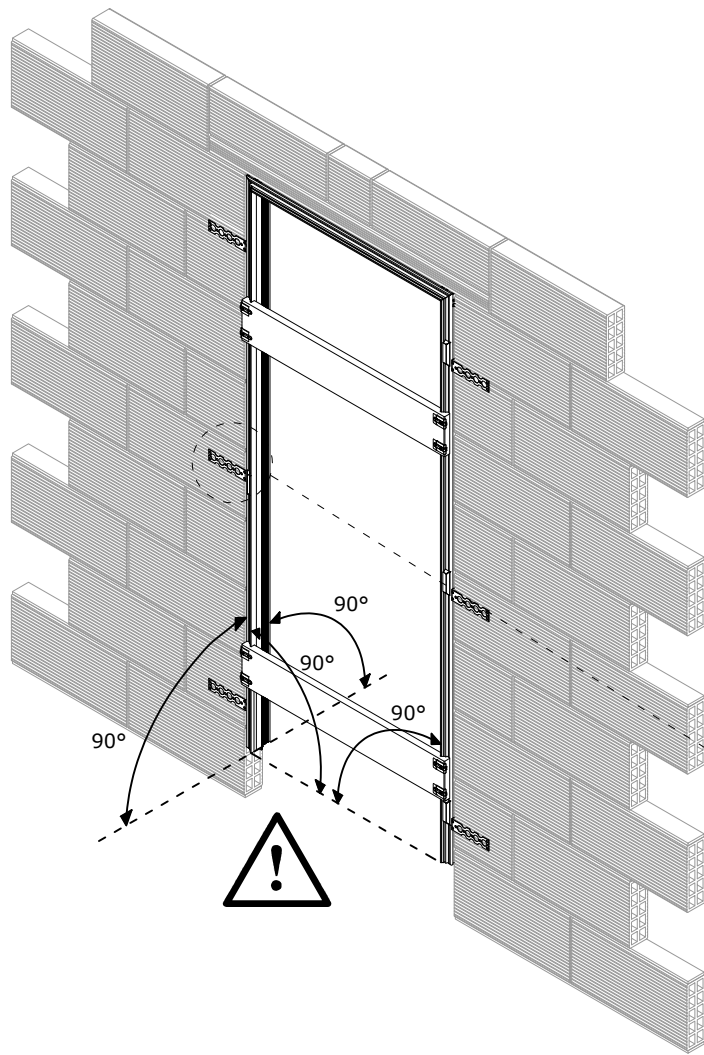

4 i

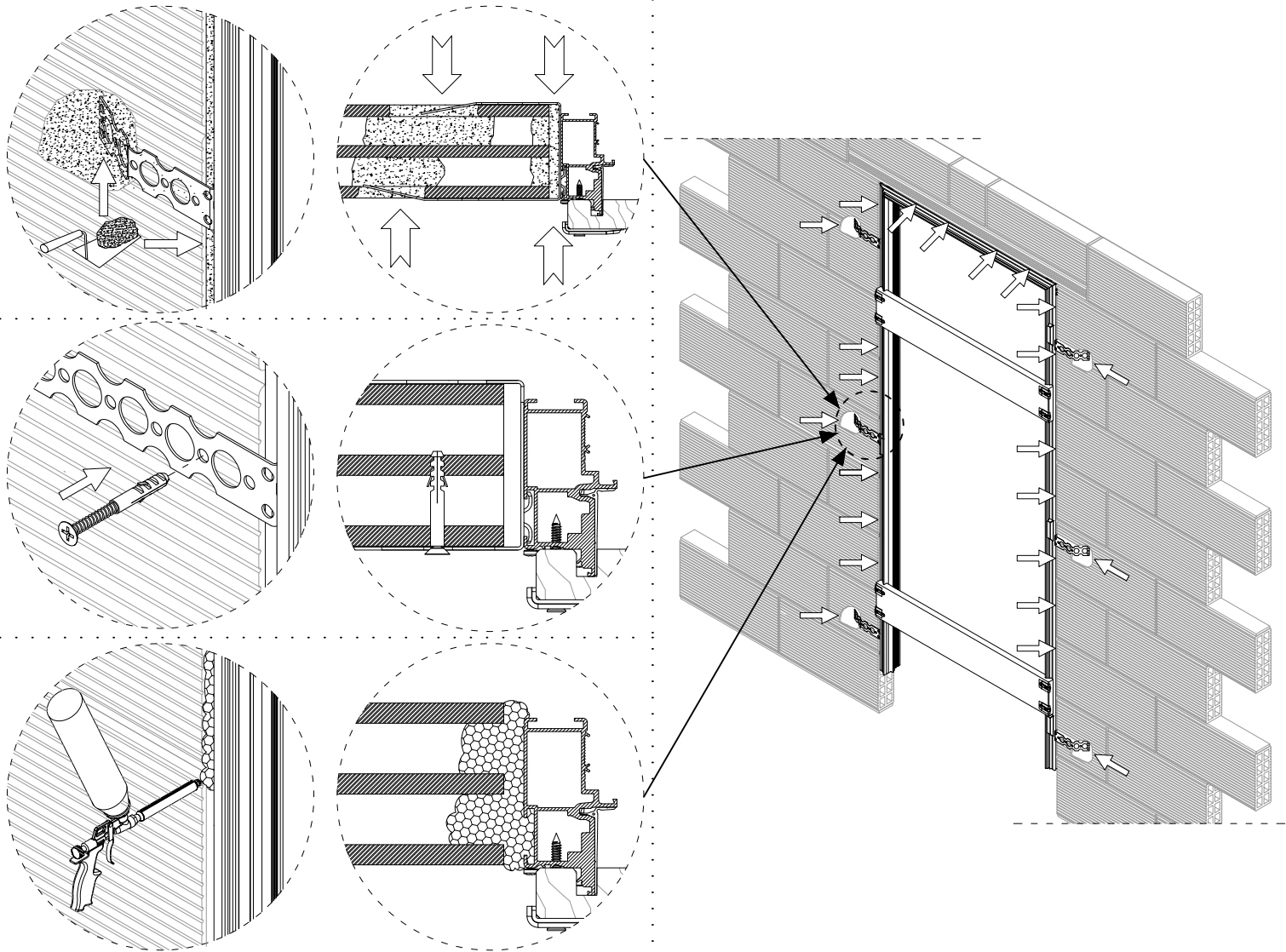

5 i

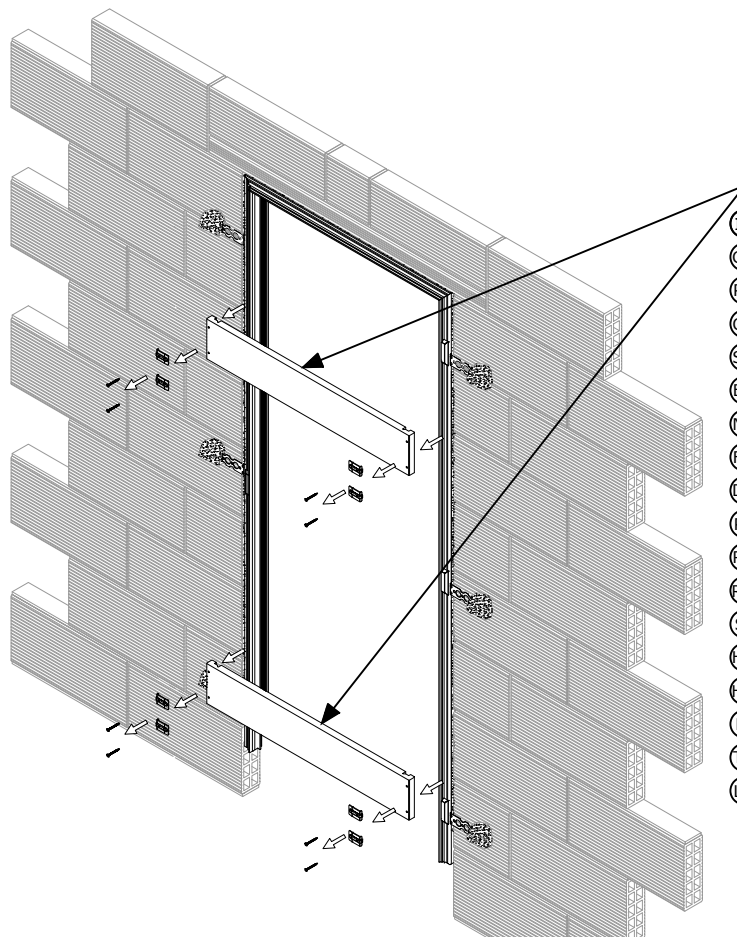
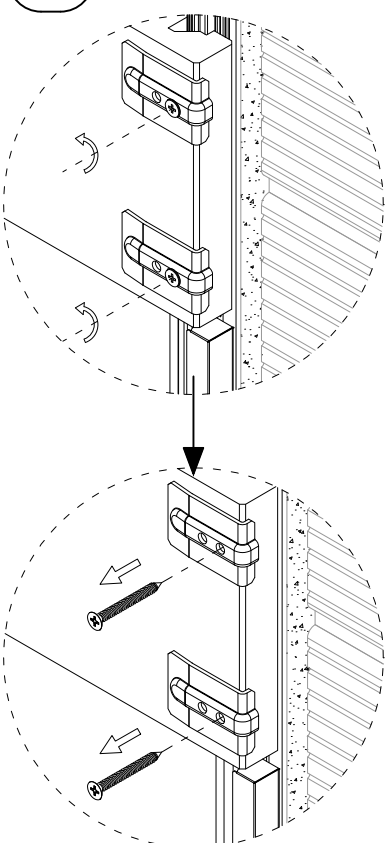

- (IT) TOGLIERE SOLO DOPO IL COMPLETO ANCORAGGIO
- (GB) ONLY REMOVE AFTER FIXING IS COMPLETE
- (PT) REMOVER SOMENTE APÓS A COMPLETA FIXAÇÃO
- (CZ) ODSTRÁŇTE AŽ PO ÚPLNÉM UKOTVENÍ
- (SK) ODSTRÁŇTE AŽ PO ÚPLNOM UKOTVENÍ
- (ES) REMOVER SOLO DESPUÉS DEL COMPLETO ANCLAJE
- (NL) PAS VERWIJDEREN NA VOLLEDIGE BEVESTIGING
- (FR) ENLEVER SEULEMENT APRÈS SÉCHAGE DES ANCRAGES
- (DE) ERST NACH KOMPLETTER VERANKERUNG ENTFERNEN
- (PL) USUNĄĆ PO CAŁKOWITYM MONTAŻU OŚCIEŻNICY
- (RU) СНЯТЬ ТОЛЬКО ПОСЛЕ ПОЛНОГО АНКЕРНОГО ЗАКРЕПЛЕНИЯ
- (RO) ÎNDEPĂRTAJI DOAR DUPĂ ANCORAREA COMPLETĂ
- (SI) SNETI LE PO DOKONČANEM SIDRANJU
- (HU) CSAK A TELJES RÖGZÍTÉS UTÁN TÁVOLÍTSA EL
- (HR) UKLONITI SAMO NAKON POTPUNOG UČVRŠĆENJA
- (FI) POISTA VASTA KUN KIINNITYS ON VALMIS
- (TR) SADECE SABİTLEME TAMAMLANDIKTAN SONRA KALDIRINIZ
- (LT) DEMONTUOTI TIK STABILIAI ĮTVIRTINUS STAKTĄ

6 i

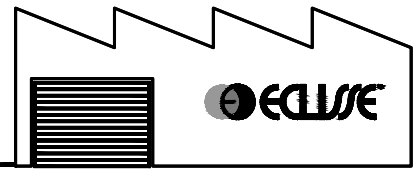
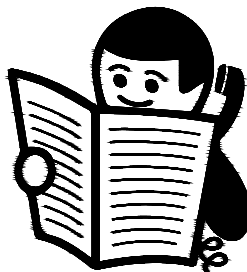
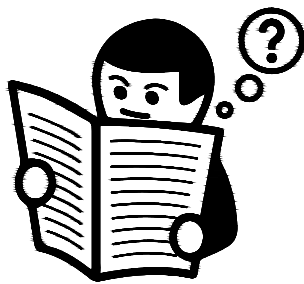
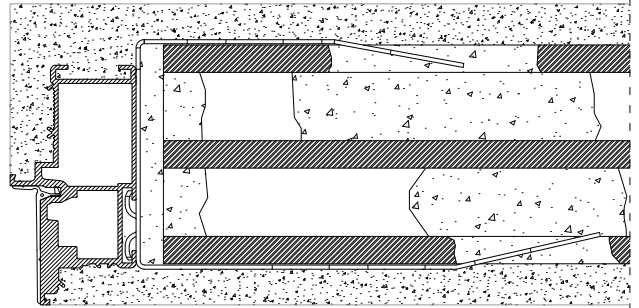
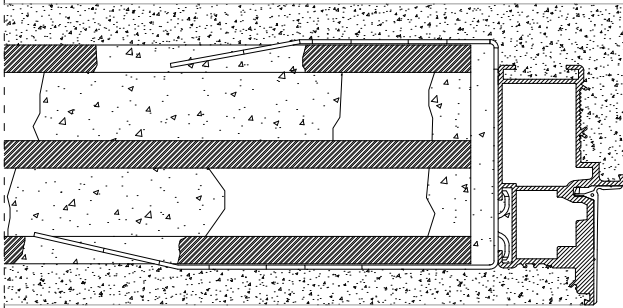
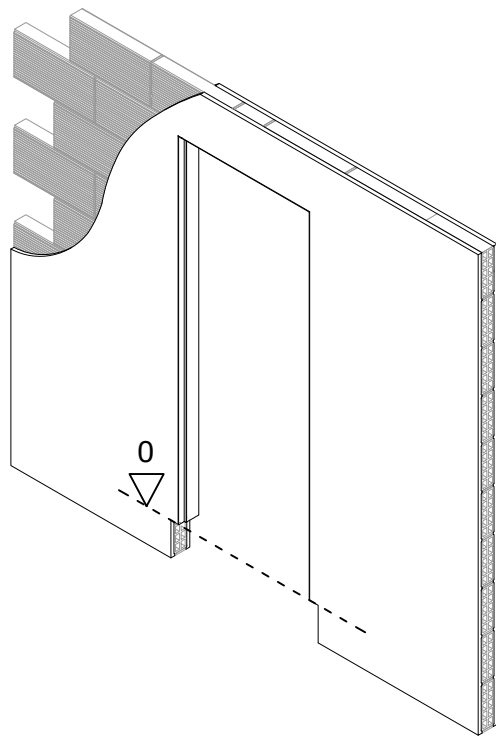

www.eclisseworld.com/en/dealer-locator

